

# Comparative Analysis of PV System Performance in Different Environmental Conditions

Muhammad Azaz<sup>1</sup>, Sajad Ullah<sup>2</sup>, Jawad Ul Islam<sup>3</sup>

<sup>1,2,3</sup>Department of Electrical Energy System Engineering, US-Pakistan Center for Advanced Studies in Energy (US-PCASE), UET Peshawar

azazkhan8511@gmail.com<sup>1</sup>, sajad.ullah@yahoo.com<sup>2</sup>, jawad\_ulislam@yahoo.com<sup>3</sup>

Received: 10 November, Revised: 15 November, Accepted: 23 November

**Abstract**— Apart from many other factors the overall performance of PV depends on temperature and solar irradiance because as the day progresses the energy received by PV panels from the sun changes and temperature also changes throughout the day. In this paper effects of temperature and solar irradiance variation were studied on a 240V PV panel's maximum power, efficiency, and fill factor. The model is designed in Simulink/Matlab software which has two variable inputs in the form solar irradiance and temperature and three output parameters i.e. efficiency, fill factor and maximum power. First the performance parameters are observed under STC conditions and then one of the input is changed from STC whereas the other one is kept constant. At the end the second input is varied whereas the first one is held at STC. Simulations were performed and results obtained in terms of maximum power, efficiency and fill factor shows percent variation from its reference value for every one degree centigrade change in temperature and for every 20W/m<sup>2</sup> change in the solar irradiance.

**Keywords**— Temperature, Irradiance, Efficiency, Fill Factor, Maximum power, Matlab/Simulink.

## I. INTRODUCTION

Because of increased energy demand and current energy crises traditional energy sources are declining and are unable to meet the energy demands of the world. Furthermore the conventional energy sources has a negative impact on our environment and causes many problems like air pollution, acid rain and greenhouse effect etc [1]. Therefore renewable energy (RE) is becoming a global source of clean and environmental friendly energy for the earth. The most common and world widely used source of renewable energy is sun. Energy from sun can be obtained by many ways like solar thermal, solar PV and solar heat. But using photovoltaic effect which is the most sustainable and essential source of renewable energy has shown a great success [2]. In Photovoltaic system electricity is generated by solar cells. A semiconductor device which directly converts solar energy to electrical energy using the PV effect is called a photovoltaic or solar cell. Photovoltaic cells are mostly made of silicon which may be non-crystalline, polycrystalline or

crystalline depending upon the efficiency of cell and cost of material used [3]. A PV panel is formed as a result of several combinations of solar cells, which are installed on the rooftop of our homes and is used at basic level. The combinations of solar panels forms PV arrays, these arrays consists of thousands of identical cells which works as a local power station, and can be used at residential, commercial and industrial level [4]. According to a report published by international agency of energy the photovoltaic (PV) is going to produce 11% of the electricity produced by the whole world, which is going to reduce the emission of carbon dioxide (CO<sub>2</sub>) by an amount of 2.3 Giga tons per annum[5]. Several environmental factors effects the performance of a PV panel like temperature, wind, humidity, solar intensity, dust and rain etc. But the two fundamental factors which changes the efficiency, fill factor and maximum power of a solar panel to a great extent are solar irradiance and operating temperature [6]. Although PV panel performance decreases with increase in temperature (T), but the temperature at standard test conditions also has a significant impact on the performance parameters of a PV panel as it has linear relation with the performance of a PV Panel [7]. In addition to temperature solar irradiance (G) also greatly impact performance parameters of a solar panel. With an increase in solar irradiance both open circuit voltage (V<sub>oc</sub>) and short circuit current (I<sub>sc</sub>) changes because of which the maximum power (P<sub>max</sub>) varies with it [8]. As these two factors have a great non-linear behavior and changes continuously at any interval of time, however temperature is directly responsible for a change in voltage of a solar panel. With an increase in temperature of the panel its voltage decreases and vice versa. Similarly current of the panel varies greatly with a change in solar irradiance of the panel [9]. Now with variation in either current or voltage or both will eventually affect the performance of a PV. The three performance parameters of a PV panel are functions of PV module current and voltage. So with variation in current and voltage, which is caused by temperature and irradiance variation, will eventually causes a disparity in performance parameters of the PV system [10].

## II. METHADODOLOGY

The system for 240V PV panel is designed in Simulink/Matlab which is very useful tool for modeling, simulation and modulation analysis of dynamic systems. The inputs to the panel are irradiance and temperature, while its output includes currents and voltages namely voltage at maximum power point ( $V_{max}$ ), current at maximum power point ( $I_{max}$ ), open circuit voltage ( $V_{oc}$ ) and short circuit current ( $I_{sc}$ ). These four parameters are very useful and are first studied under STC then at varying temperature (21oC to 29oC) and at the end at varying irradiance (0.92KW/m<sup>2</sup> to 1.08KW/m<sup>2</sup>). The performance parameters are then measured with the help of these basic parameters.

### A. Open circuit voltage

It is the maximum available voltage at the output of the PV panel at no load. The net current at  $V_{oc}$  inside PV is zero. The  $V_{oc}$  is dependent on temperature and irradiance and is given by the following equation.

$$V_{oc} = V_{oc0} + D.Vt. \log(G/G_0) + K_v.(T - T_0) \quad (1)$$

Here  $V_{oc0}$  is STC conditions open circuit voltage,  $D$  is diode ideality factor,  $T$  and  $G$  are the respective temperature and irradiance values at which  $V_{oc}$  is measured,  $K_v$  (-0.369%/oC) represents the temperature coefficient of voltage and  $Vt$  is the terminal voltage which is given by

$$Vt = (N_s.K_b.T)/q \quad (2)$$

Here  $N_s$  (60) is the number of cells per module and  $K_b$  is the Boltzmann constant ( $1.3806 \times 10^{-23} \text{Kg.m}^2.\text{K}^{-1}.\text{s}^{-2}$ ) and  $q$  represents electronic charge ( $1.602 \times 10^{-19} \text{C}$ ).

### B. Short circuit current

It is the output current at zero voltage i.e. when the panel is short circuited. It is the highest value of y-axis at I-V curve when then the x-axis value is zero. It is also dependable on temperature and irradiance. The equation of  $I_{sc}$  is given by

$$I_{sc} = (G/G_0).(I_{sc0} + K_i(T - T_0)) \quad (3)$$

Where  $I_{sc0}$  is STC condition short circuit current and  $K_i$  represents the temperature coefficient of current (0.087% /oC). The above equation clearly indicates that the effect of solar irradiance will be more as compare to that of the temperature, which is exactly converse of its effects on  $V_{oc}$ .

### C. Voltage at maximum power point

It is also known as peak power voltage and it is the actual maximum voltage available at the output when the system is under loaded condition. Like the open circuit voltage  $V_{max}$  also depends on temperature and solar irradiance except that it has no diode ideality factor and its equation is written as

$$V_{max} = V_{max0} + Vt. \log(G/G_0) + K_v.(T - T_0) \quad (4)$$

### D. Current at maximum power point

The current at which a PV panel generates maximum power is known as its maximum current ( $I_{max}$ ). Its value is also depends upon the behavior of temperature and irradiance. The

relationship between  $I_{max}$  and the two input variables is given by the equation.

$$I_{max} = (G/G_0).(I_{max0} + K_i(T - T_0)) \quad (5)$$

## III. PERFORMANCE PARAMETERS

### A. Maximum power produced by the panel

The maximum output power of a panel which is represented by the knee of a V-I curve is known as maximum power ( $P_{max}$ ) of that PV panel. The maximum power of a panel is mainly affected by open circuit voltage ( $V_{oc}$ ) and short circuit current ( $I_{sc}$ ), and both these terms are directly varied by temperature and solar irradiance. So this means that  $P_{max}$  is dependent on temperature and solar irradiance. it is first observed on STC conditions then temperature is varied from STC ( $T_0=25\text{oC}$ ) and irradiance is kept constant and then solar irradiance is varied from its STC ( $G_0=1000 \text{ W/m}^2$ ) and temperature is kept constant.

### B. Efficiency of the panel

The measure of sunlight energy which is directly convertible to electrical energy through photovoltaic effect is known as Efficiency ( $\eta$ ) of a solar panel. Mathematically it is the output to input power ratio of a PV panel.

$$\eta = P_{out}/P_{in} \quad (6)$$

Where  $P_{out}$  is the electrical power output and can be represented as the product of  $I_{max}$  and  $V_{max}$

$$P_{out} = I_{max}.V_{max} \quad (7)$$

$P_{in}$  represents power input from sun which represents the amount of sunlight energy ( $G$ ) in  $\text{W/m}^2$  which strikes surface area ( $A$ ) of PV panel and is given as

$$P_{in} = A.G \quad (8)$$

So PV panel efficiency will be written as

$$\eta = V_{max}.I_{max}/A.G \quad (9)$$

From the above equation it is clear that efficiency of PV is dependent upon the surface area  $A$ , solar irradiance  $G$  and temperature  $T$  because  $I_{max}$  and  $V_{max}$  both depends on temperature.

### C. Fill factor of the panel

The quality measure of a PV is known as its Fill factor (FF), which compares maximum power produced by a PV to theoretical power of that PV. The maximum power can be written as a product of its maximum power point voltage and current while theoretical power represents product of  $V_{oc}$  and  $I_{sc}$ .

$$FF = I_{max}.V_{max} / I_{sc}.V_{oc} \quad (10)$$

In the above equation all four parameters that makes up the fill factor are dependent on irradiance and temperature, which indicates that fill factor is an indirect function of both these variable parameters.

**Table 1.** Panel parameters

Parameter	Rating
1soltech 1STH-240-WH	240V
Maximum power (Pmax)	239.679V
Voc	37.1V
Isc	8.58A
Vmax	29.7V
Imax	8.07A
Numbers of cells per module (Ns)	60
Temperature coefficient of Voc (Kv)	-0.369%/°C
Temperature coefficient of Isc (Ki)	0.087%/°C
Diode ideality factor (D)	1.0133
Area of module (A)	1.63m <sup>2</sup>
Efficiency of module (η)	14.7%
Fill factor (FF)	0.753
STC temperature (To)	25°C
STC irradiance (Go)	1000W/m <sup>2</sup>

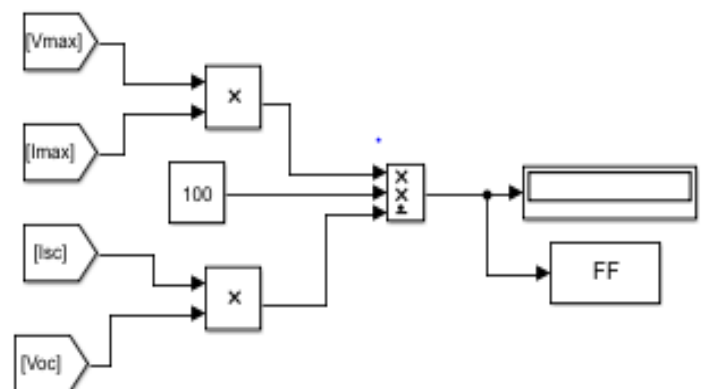
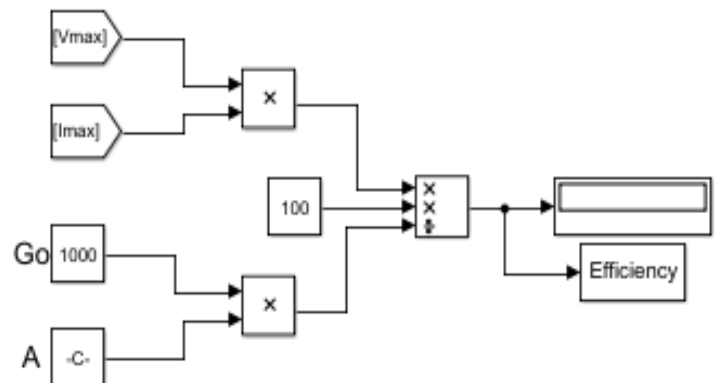
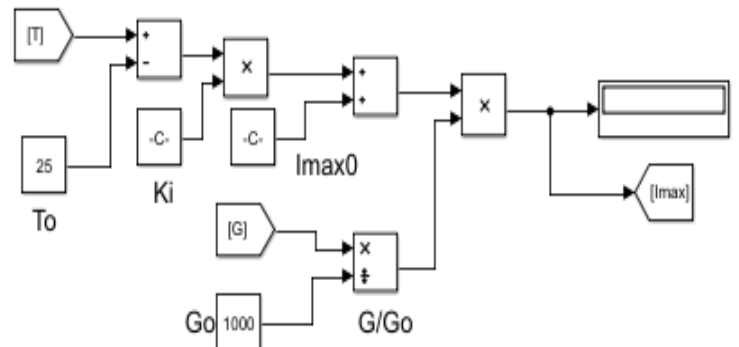
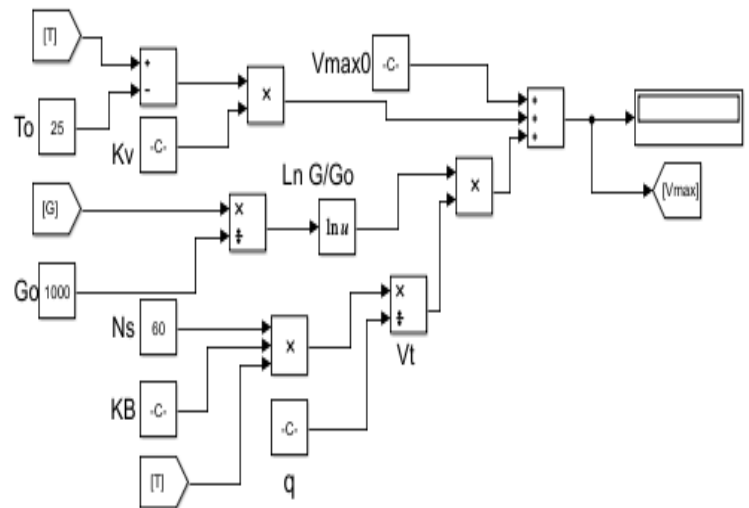
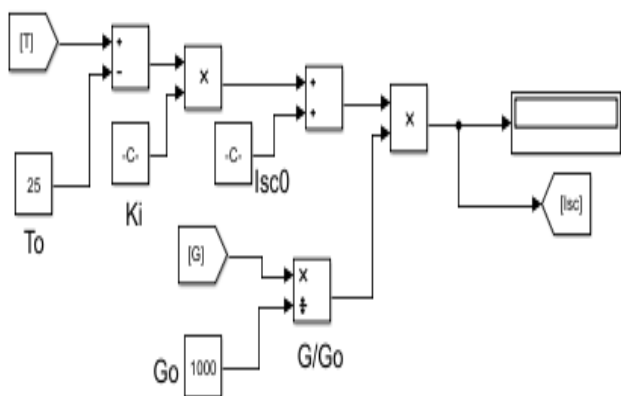
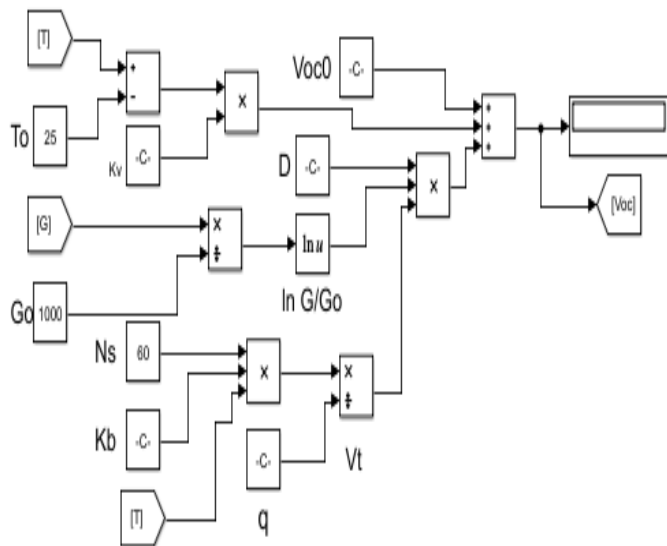

#### IV. RESULTS

The results of maximum power, efficiency and fill factor were observed under varying temperature and solar irradiance. The results of maximum power are obtained from the I-V curve at various different irradiance and temperature while that of efficiency and fill factor are noted from model designed in Simulink.

##### A. Results of maximum power

The maximum power results are noted under two different scenarios. In first scenario temperature is varied below and above of its STC values ranging from 21oC to 29oC at constant irradiance. In this case by increasing temperature maximum output power decreases and vice versa. But overall change in power is very small, it is because when the temperature is increased then there is a decrease in open circuit voltage and a slight increase in short circuit current but the decrease in Voc is large as compared to the increase in Isc and as a result Pmax decreases and vice versa. In second scenario variation of irradiance from 920W/m<sup>2</sup> to 1080W/m<sup>2</sup> with an interval of 20W/m<sup>2</sup> indicates that by increasing solar irradiance there is an increase in short circuit current whereas open circuit voltage remains nearly constant and as a result maximum output power of the PV panel increases.

##### B. Results of efficiency

The efficiency ( $\eta$ ) of 240V panel under variable temperature indicates that if there is an increase in PV panel temperature, then efficiency of panel decreases and vice versa. This is due to the fact that efficiency is dependent on I<sub>max</sub> and V<sub>max</sub> and by increasing temperature these two variables also vary. With temperature increase, I<sub>max</sub> increases slightly and there is a significant decrease in V<sub>max</sub> due to which there is a slight decrease in the efficiency of the panel. The efficiency under variable irradiance shows that if solar irradiance of the panel is increased then the efficiency of the panel also increases and vice versa. The reason for this is that by increasing solar irradiance there is an increase in maximum current while maximum voltage decreases but the increase in the I<sub>max</sub> is more significant than the decrease in the V<sub>max</sub>, so the efficiency of the panel increases significantly.

##### C. Results of fill factor

The fill factor of 240V panel under temperature variations shows that if temperature is increased at constant solar irradiance then there is a decrease in fill factor and vice versa. As fill factor represents the ratio of maximum power point current and voltage to the short circuit current and open circuit voltage. So if temperature is increased then both the voltages decrease and both the currents increase and the product of respective current and voltage changes. The voltages decrease in a proportional manner but the increase in Isc is more compared to increase in maximum current due to which the FF of panel decreases. Fill factor under varying irradiance indicates that by increasing solar irradiance the FF also increases and vice versa. This is because that by increasing solar irradiance both the voltages increase slightly and both the currents decrease significantly but the overall change in the FF is very small at this very little change in the solar irradiance.

#### CONCLUSION

Along with many more advantages there are several challenges to the PV system. One of the significant challenge is its too much dependency on whether conditions and installed location. In this paper a 240V PV panel performance is studied in variable temperature and solar irradiance conditions using Simulink environment. The performance parameters were first studied under STC conditions. Now the variation in either temperature or irradiance or in both will eventually cause a variation in maximum power point current and/or maximum power point voltage and/or open circuit voltage and/or short circuit current, which eventually causes variations in maximum power, efficiency and fill factor. If irradiance is held at constant and temperature is increased from its STC value then its maximum power, efficiency and fill factor decreases and vice versa. Similarly if temperature is kept constant and there is an increase in irradiance then all these three parameters also increase and vice versa. For every one degree change in the temperature of 240V PV panel there is an average change of 0.38% in the maximum power, 0.12% in the efficiency and 0.18% in the fill factor. Similarly for every 20W/m<sup>2</sup> variation in solar irradiance of 240V PV panel there is an average change of 1.91% in the maximum power, 2.0% in the efficiency and 0.0017% in fill factor. From the above statistics it is clear that the effect of variation in temperature mostly affects the maximum power and that in solar irradiance effects efficiency of PV panel.

In future the proposed model can be used for any different ratings PV panel or for any other PV system. Furthermore it can also be used with variation in both temperature and irradiance at the same time.

#### REFERENCES

- [1] Darwish, Z.A., et al., Impact of some environmental variables with dust on solar photovoltaic (PV) performance: review and research status. *International J of Energy and Environment*, 2013. 7(4): p. 152-159.
- [2] Singh, G.K., Solar power generation by PV (photovoltaic) technology: A review. *Energy*, 2013. 53: p. 1-13.
- [3] Pandiarajan, N. and R. Muthu. Mathematical modeling of photovoltaic module with Simulink. in 2011 1st International Conference on Electrical Energy Systems. 2011. IEEE.
- [4] Touati, F., et al., Investigation of solar PV performance under Doha weather using a customized measurement and monitoring system. *Renewable Energy*, 2016. 89: p. 564-577.
- [5] Aksakal, A. and S. Rehman, Global solar radiation in northeastern Saudi Arabia. *Renewable Energy*, 1999. 17(4): p. 461-472.
- [6] Kim, I.-S., Robust maximum power point tracker using sliding mode controller for the three-phase grid-connected photovoltaic system. *Solar Energy*, 2007. 81(3): p. 405-414.
- [7] Van Dyk, E., et al., Temperature dependence of performance of crystalline silicon photovoltaic modules. *South African Journal of Science*, 2000. 96(4).
- [8] Kawajiri, K., T. Oozeki, and Y. Genchi, Effect of temperature on PV potential in the world. *Environmental Science & Technology*, 2011. 45(20): p. 9030-9035.
- [9] Dubey, S., J.N. Sarvaiya, and B. Seshadri, Temperature dependent photovoltaic (PV) efficiency and its effect on PV production in the world—a review. *Energy Procedia*, 2013. 33: p. 311-321.
- [10] Kane, A.N. and V. Verma, Performance enhancement of building integrated photovoltaic module using thermoelectric cooling. *International Journal of Renewable Energy Research (IJRER)*, 2013. 3(2): p. 320-324.

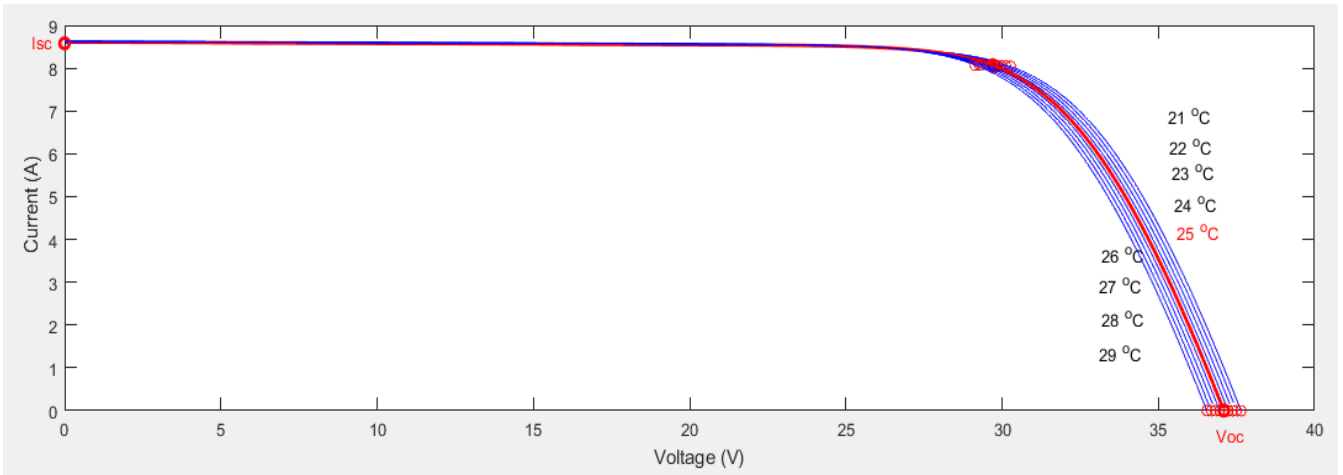

**Figure 1.** V-I curve at various temperatures from which Pmax is found

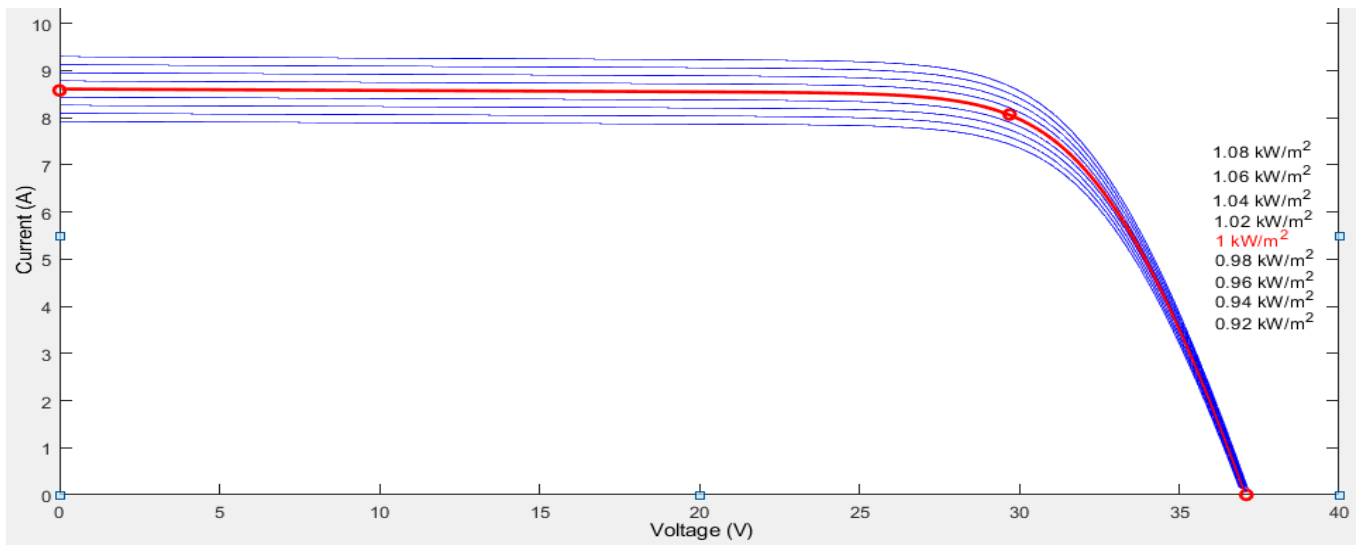

**Figure 2.** V-I curve at various irradiances from which Pmax is found

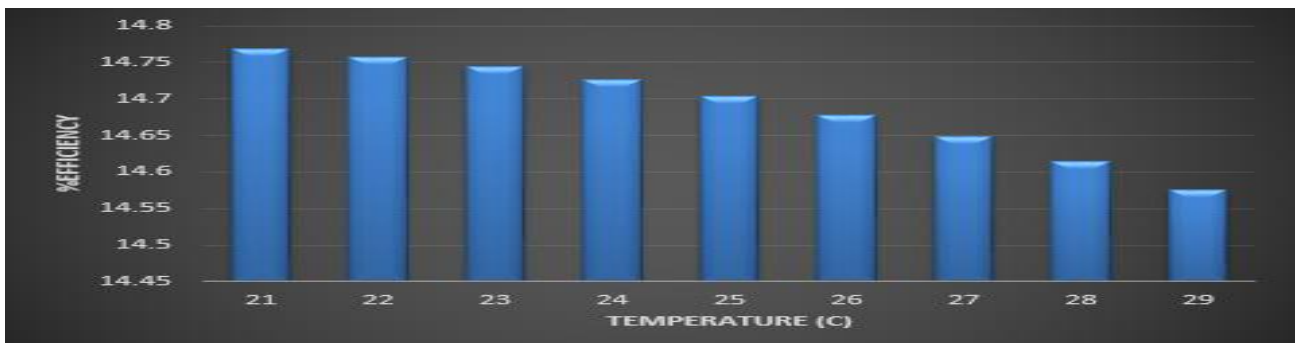

**Figure 3.** Efficiency at different temperatures

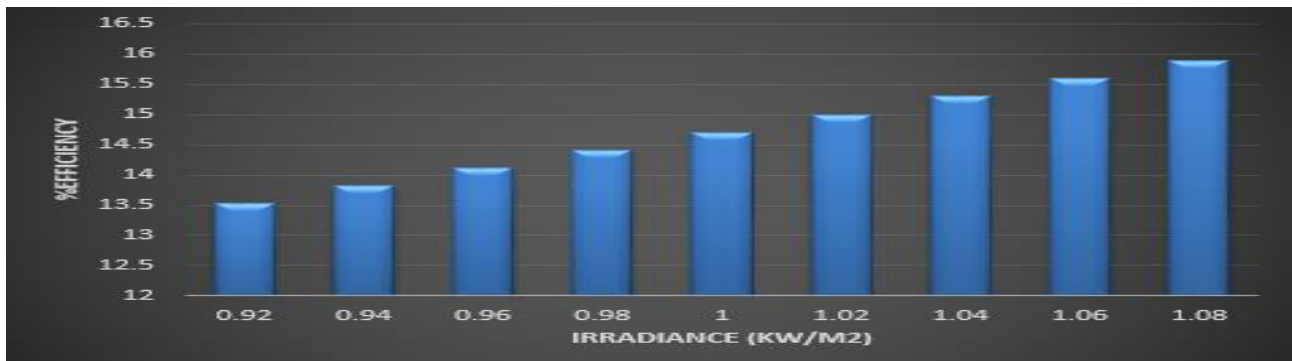

Figure 4. Efficiency at various irradiances

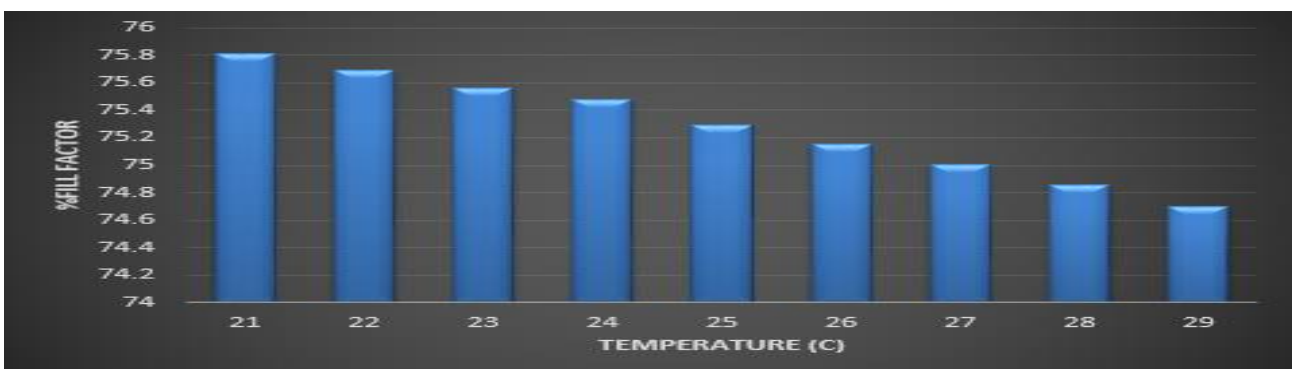

Figure 5. Fill factor at various temperatures

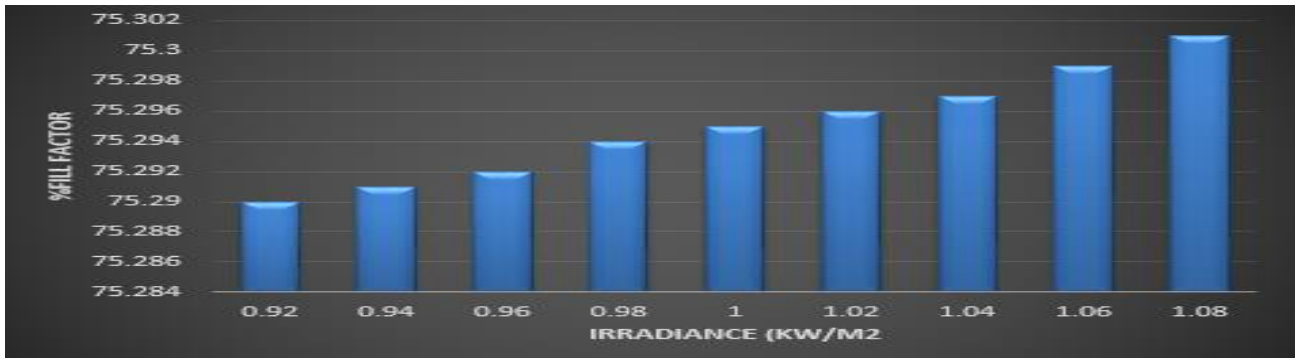

Figure 6. Fill factor at different irradiances

Table 2. Parameters against temperature

T(°C)	21	22	23	24	25	26	27	28	29
V <sub>m</sub>	31.176	30.807	30.438	30.069	29.700	29.331	28.962	28.593	28.224
I <sub>m</sub>	7.721	7.808	7.895	7.962	8.070	8.157	8.244	8.331	8.418

Voc	38.576	38.207	37.836	37.469	37.100	36.731	36.362	35.993	35.624
Isc	8.231	8.318	8.405	8.492	8.580	8.667	8.754	8.841	8.928
Pm	243.40	242.40	241.41	240.30	239.70	238.20	237.30	236.21	235.20
% $\eta$	14.769	14.758	14.744	14.726	14.704	14.678	14.648	14.614	14.576
FF	75.810	75.688	75.562	75.481	75.295	75.154	75.008	74.857	74.701

**Table 3.** parameters against irradiance

G(W/m <sup>2</sup> )	920	940	960	980	1000	1020	1040	1060	1080
Vm	29.689	29.692	29.694	29.697	29.70	20.702	29.705	29.707	29.709
Im	7.424	7.585	7.747	7.908	8.070	8.231	8.392	8.554	8.715
Voc	37.089	37.091	37.094	37.097	37.100	37.102	37.105	37.107	37.110
Isc	7.893	8.065	8.236	8.408	8.580	8.751	8.923	9.094	9.266
Pm	220.80	225.50	230.10	234.70	239.70	243.90	248.40	253.00	257.50
% $\eta$	13.522	13.813	14.113	14.408	14.704	14.999	15.295	15.590	15.885
FF	75.290	75.291	75.292	75.294	75.295	75.296	75.297	75.299	75.300

**How to cite this article:**

Muhammad Azaz, Sajad Ullah, Jawad Ul Islam, "Comparative Analysis of PV System Performance in Different Environmental Conditions", International Journal of Engineering Works, Vol. 7, Issue 11, PP. 394-3400, November 2020, <https://doi.org/10.34259/ijew.20.711394400>.

