

Comparative Analysis of Virtual Inertia Techniques in Wind Energy

Adnan Ismail¹, Saddam Ali¹, Abdul Basit¹

¹United States Pakistan Center for Advanced Studies in Energy UET Peshawar, Pakistan

Received: 09 January, Revised: 16 January, Accepted: 24 January

Abstract— Recent decades have seen an incline in integration of wind energy in to power systems across the world. This invariably leads to lower share of conventional power plant which subsequently reduces the grid's inertia as a consequence of the decoupling rotational mass of the variable speed turbines and grid through power electronic converters. Accordingly, the overall system inertia is lowered leading to more frequent and intense frequency variations concomitant with the variation in the load. This research focuses on alleviating the rotational mass and inertia related problems caused by increasing wind power integration by adding an inertial loop to compensate the impact of frequency deviations due to abnormal transient conditions. The virtual inertia, thus added, reduces maximum rotational speed deviation while at the same time making the system slower and more oscillatory. The simulation consists of addition of synchronous generator capable of adapting its power output to the fluctuations in grid loads. A load step has been added for analyzing the performance improvement of the system as a result of the virtual inertia addition. The simulation has been modeled in Simulink MATLAB. The addition of the inertial power results in the improving the frequency drop from 58.42 to 59.31 Hz. This stabilization of 0.9 Hz carries a lot of significance for improving grid stability. In addition the angular speed of the turbine has also been enhanced as a result of the virtual inertia. These findings will prove extremely helpful in offsetting the drawbacks of greater wind energy addition to grid. The analysis needs to be further replicated with other transient conditions before being implemented in the grid.

Keywords— Virtual Inertia, Renewable Energy, Wind Turbine

I. INTRODUCTION

Energy being the necessity for driving human life its secure and accessible supply is critical for progressing of modern developing societies. Increase in population and evolution of societies has increased the demand for energy. Constant use of fossils fuels for energy generation, transportation, industries and other works of modern-day life will lead the world towards multiples challenges like depletion of natural reserves, global warming, climatic changes and geopolitical concerns. Exponential increase in global energy consumption needs to be met without implicating environment damage shows existing energy sources will not be sufficient for the future requirements and we should look for unorthodox ways to harness energy and not endanger the life of current and future generation [1].

Global energy demand according to International Energy Agency will increase 35% by 2035 where 60% of increase would be contributed by China, India and Middle East. The push of incorporating renewables in power system is due to the global concern about the negative impacts of global warming, motivating the countries around the world to produce clean and cheaper electricity [2]. The shift from producing electrical energy from fossil fuels to producing energy from more environment friendly cheaper and readily available sources impact of carbon emissions due to burning oil or coal and environmental effects due to nuclear and hydroelectrical power plants can be reduced [3].

Intergovernmental Panel on Climate Change (IPCC) predicts vital changes in energy supply should be done in near future to prevent more than 2 degrees Celsius climate change which is boundary line above which human civilization and natural world will be at risk of disastrous changes. Genesis of half the global warming pollution is due to burning of fossil fuels for electricity production. Industries in general accounts 78% green house gases accumulating in atmosphere and trapping heat. In the last four decades human population amassed half of global pollution which is in the air we breathe severely affecting health and climate change [3].

Alternative energy sources solar, wind, biomass and geothermal energy are inexhaustible and widely available and have potential to meet world energy needs. To bring diversity in energy markets, sustainability in energy supplies, reduction in environmental effects, development and utilization of renewable energy sources are very critical. Solar and wind energy systems have grown exponentially in the last decade which have resulted in comparatively less initial investment, cost of electricity and more refined functioning of these systems. Amount of energy production from different available resources all over the world for year 2016 is show in Fig.1 [1].

Competition among countries have erupted that who will be the first country to utilize only renewable energy for 100% of the demand occurring. China has by far largest installed capacity of wind of all the countries. During first half of 2018 Germany produced enough renewable energy to power every household in country for a whole one year. Denmark, Portugal, Spain, Ireland and Germany have static electricity production of 39%, 18%, 16%, 14% and 9% respectively from wind energy [4].

World gross electricity production, by source, 2016

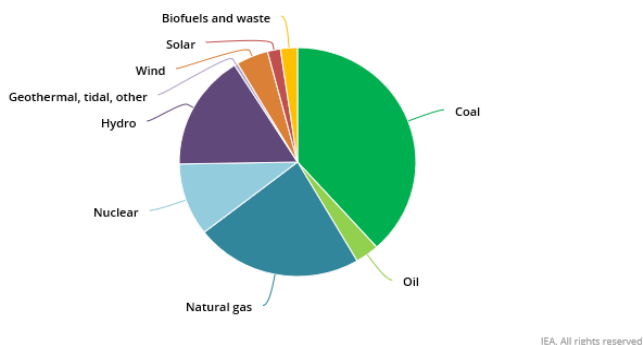

Figure.1 World Gross Electricity Production by Source, 2016

Conventional power plants are designed with large central controlled systems which are stable and more reliable compared to renewable power generation whom are distributed and independently controlled and their integration in power system confronts various challenges, uninterrupted power supply and impact of stability. Power quality issues arise from grid connected renewable generation as level of penetration increases, high fluctuations due to unstable nature of renewable sources can confront serious quality concerns. Unstable nature of these sources is because of varying weather conditions which also have an impact on the voltage and frequency fluctuation at interconnected power grid and transmission systems [5].

Power generated from sources solar photovoltaic (PV) system and wind turbine needs sunlight and wind to operate. Uncontrollable varying of the sunlight and wind gives inconsistent generation. Compared to solar power wind is less variable and changes occurs over hours not in seconds as in case of solar due to cloud cover. This fluctuating generation in turn needs instantaneous additional energy to balance out the supply and demand of power grid and frequency regulation and voltage support on transmission side. Improved weather forecasting can help predict the varying nature and help generate energy from solar and wind more accurately [5].

One of the major challenges with renewable power system is having less amount of rotational mass compared to conventional power systems which leads us to the minimum amount of inertia to maintain the proper operation and sustain any sudden changes in load and power generation. Wind power Systems must have greater flexibility to house the variation in supply side the generation limits and loads should be in synch. Sometimes with increase in load generation increases, but when wind generation increases, and load levels suddenly falls system needs to take additional control actions to balance gap between generation and demand. Adequate fast acting reserves needed to sustain up or down ramps of wind generation to keep system in equilibrium [6].

Charles Brush in 1888 was first to attempt generating electricity using wind turbine in United States. Turbine

generated by brush had a diameter of 17meters and 144 rotor blades with generating capacity of 12kw power. Wind power like other renewable sources has gained importance in recent years. Generating energy from wind is increasing rapidly and large investments are done in increasing installed capacity. Marcellus Jacobs developed one of the first practical fault tolerant wind turbine system which had airfoil shaped blades and wane to keep the turbine in face of the wind. Types of wind turbines are differentiated from each other by orientation of their rotational axis. Horizontal axis wind turbines (HAWTs) are the most commonly used wind turbine which have evolved during the 20th century resulted in bigger, durable and advanced turbines. Vertical axis wind turbines (VAWTs) though having potential fell victim to the poor energy market or lack of interest and financial support kept away from public association. Vertical axis wind turbines are more suitable for tidal current power conversion [7].

Renewable energy technologies like solar and wind energy plants has little to zero inertia constant compared to power plants generating power from traditional sources. Wide adoption of these technologies and increase in share of global power generation is decreasing the rotating mass of synchronous generators, which has a significant effect on the stability and potential of power system in maintaining the frequency in desired limit during sharp changes in generation and load [8]. These sudden load changes in conventional power plants are compensated through the kinetic inertia stored in rotor of the generator but in wind power plants virtual inertia method is implemented which imitates synchronous generator kinetic inertia to improve the dynamic response of the system [8].

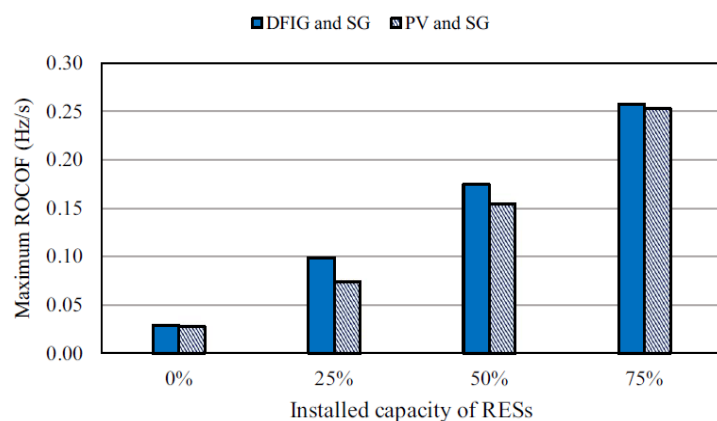

Figure 2: Increase in the rate of change of frequency in relation to different levels of RES integration

the integration of renewable energy system in a country's power system, in addition to increased reliability and improved voltage profile of the grid, also decrease the use of fossil fuel thus proving a net positive for the adopters [16-19]. The increasing penetration of the RESs however has been hampered by the concomitant challenges, such as frequency and inertia [20]. The challenges are manifesting in many forms. To start with the renewable energy systems are

generally regarded as low or nonexistent inertial response systems [21]. This is in part due to the fact that the wind turbines, being variable speed, are connected with the power network via power electronic converters, leading to practical decoupling of the wind turbine and the associated inertia from the system transient behavior. This ultimately leads to the overall reduction of power system inertial with increase in the RES integration_ a fact supported by the example of simulation on UK's energy system where researchers forecasted a decrease of inertia constant of the system by 70%

between 2013/14 and 2033/34 as a direct outcome of increased renewable energy systems [22,23]. Consequently, the ROCOF (Rate of Change of Frequency) factor will be high enough to warrant power disconnection even in small imbalance situations. Figure 2 shows the ROCOF variation relative to the increased penetration of the renewable energy scenarios in a power grid covering 3.8 MW demand [24]. It is obvious that higher proportion of renewable energy systems in the grid leads to higher ROCOFs.

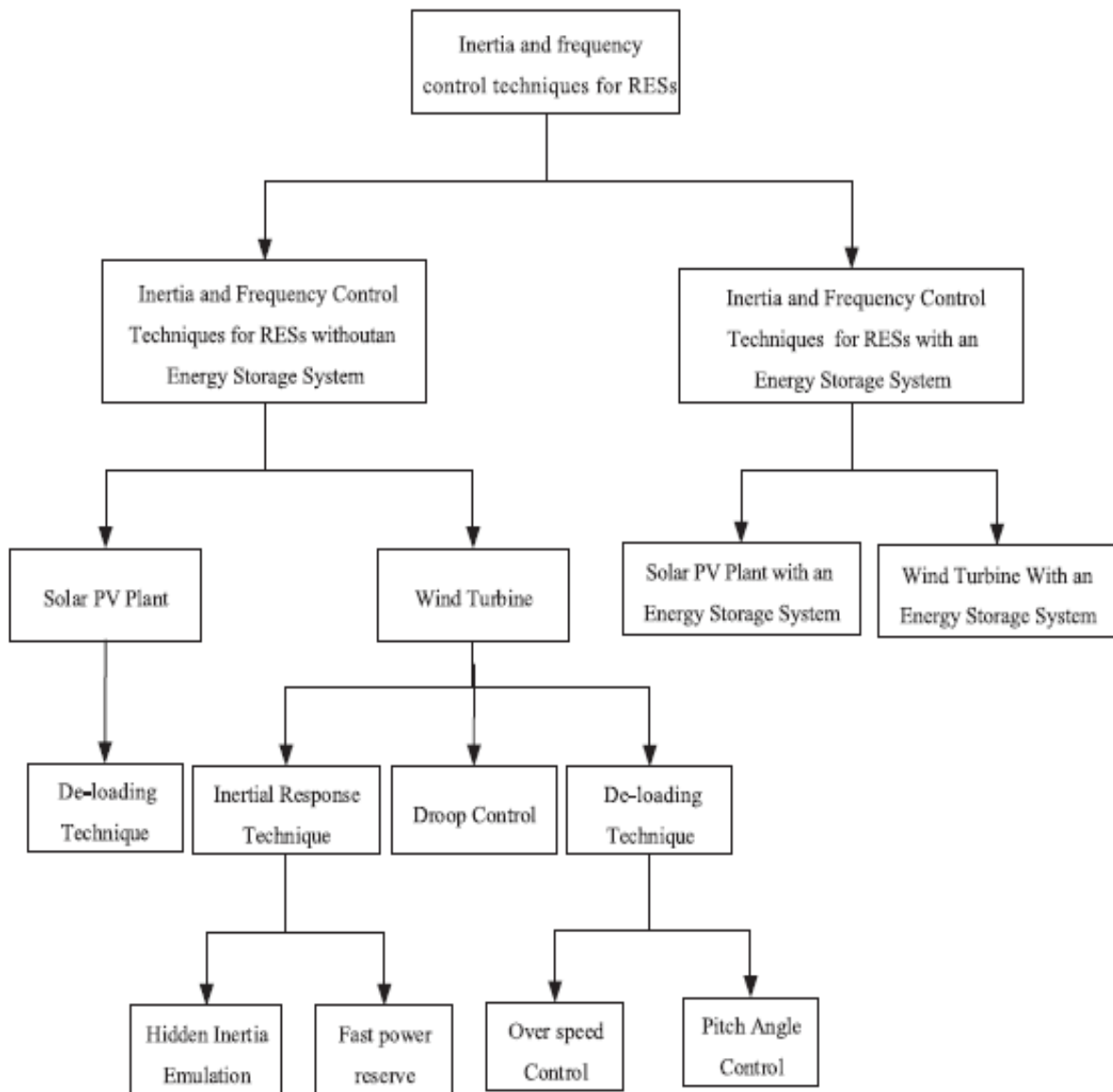

Figure 3 Renewable energy systems frequency and inertia control systems

Inertial control in wind power plants enables the release of the kinetic energy within 10 seconds of the frequency deviation in contrast to the reserve control system where pitch angle, and speed control or the combination of both results in balancing

power output of the power plants. The general overview of the inertia response controls in RESs is shown in the figure 3.

The generator in the conventional power plants automatically releases the stored energy as per requirements, hence achieving stable operation. The wind power turbine, however, do not have the luxury hence necessitating a power controller. The inertia response is usually dealt with in two manners: Inertial emulation and fast power reserve. The former utilizes control loops for extracting kinetic energy stored in the blades upon requirements. The additional energy thus released compensates for the frequency disturbances. The later technique releases a predetermined constant power for a designated time to deal with the fluctuating frequency.

II. METHODOLOGY

Wind turbine used in this study is Doubly-fed Induction generator DFIG which is implemented for varying wind

speeds. Wind turbine increasing penetration in power grid doesn't have effect on the frequency up and down. Responsibility of frequency regulation and automatic generational control lies on conventional generator to keep it in specified limit. Hence wind turbines do not increase or decrease their energy production when the frequency rise or falls, ultimately contributing nothing to the system inertia. DFIG turbines however has ability to deliver power and instantly reduce speed to release the stored kinetic energy to Block Diagram of proposed Wind Turbine System with Inertial Support help support conventional generator in restoring frequency to stable limits [50].

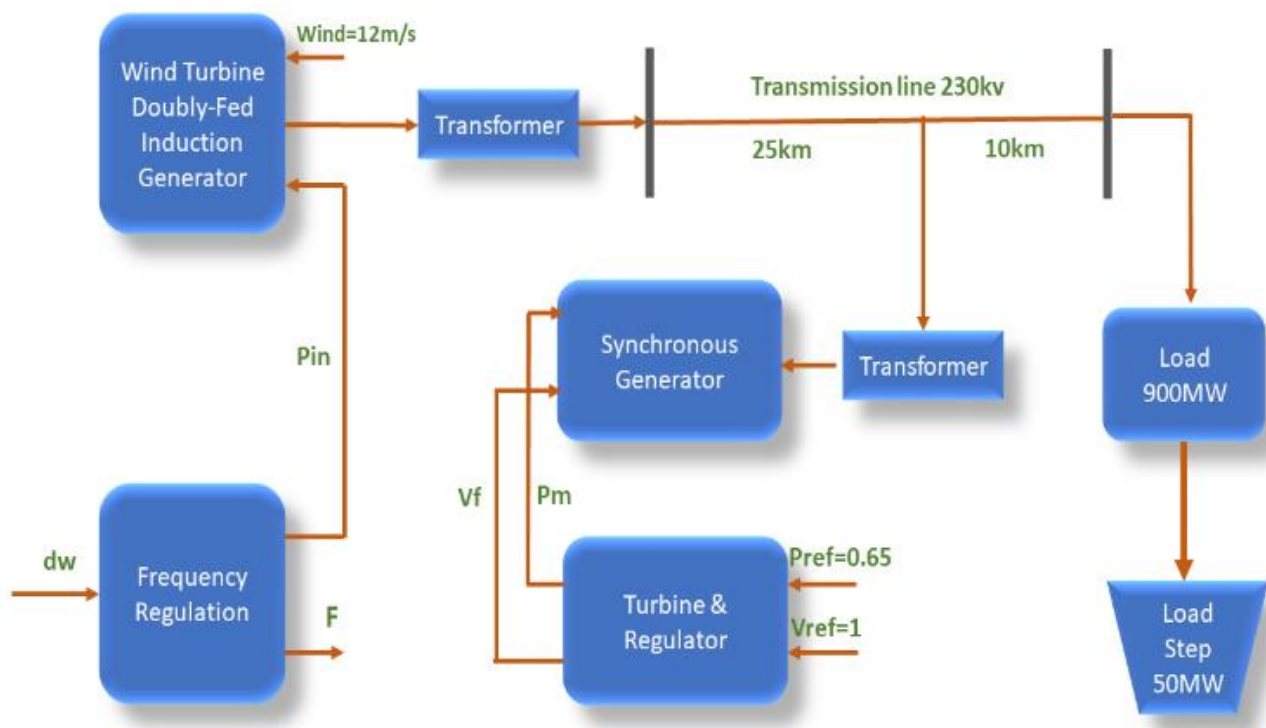

Figure.4 Block Diagram of proposed Wind Turbine System with Inertial Support

Wind turbine selected has the capacity of 225MW and wind set at 12m/s with 45 degree maximum pitch angle. Frequency for all the equipment is set at 60hz. A synchronous generator of capacity 900MVA connected with grid through the transmission line to provide the needed power in case of any unprecedented load changes or total fall. Synchronous Generator is not operating at its full capacity but at $P_{ref} = 0.65$ meaning the generator is operating at 585MW. A load of 930MW is also connected with grid and a load step of 50MW is introduced in the system at 100sec in the operation of the whole 150sec simulation.

All over the world it's a common practice of modern power system operator to reduce the rotational mass and replacing them with more efficient modern ways of producing power. Increasing use of power electronic converters due to the increasing penetration of renewable has led to the changing dynamic behavior of the power system. Renewable generating units, rotational mass from the grid are disassociated because they are connected via power electronic converter. Which lead the system operators to challenges; large power swings and frequency deviations [51].

Synthetic inertia is first line of defense to resist decreasing alternating current AC frequency which usually occurs due to tripping of large power plant which leaves the grid undersupplied consequently leaving the AC frequency to crash. Conventional power plants or synchronous generators have the capability to abruptly responds to the dips in frequency because of spinning turbines momentum whom are synched with the grid and resist any deceleration. Turbines momentum resist decrease in frequency, giving the power system precious secs to runup power reserves and fill the resulting supply gap [52].

Some studies show that negative grid stability can be upto an extent compensated by the renewable energy generators fast frequency response or by providing virtual inertia, but delay in response to the frequency change and the technology still in development compels the system operators to have some amount of synchronous generation for stability. Therefore synchronous generators are used in high renewable penetration power systems for inertial support [53]. Main advantage of synchronous generator is its physical inertia which can withstand changes in the grid parameters. Grid frequency can be measured from the generator speed of any generator

connected on the synchronous grid. For any large shock like failure of power plant or transmission line the faster the rate of change of frequency, therefore grid needs inertia for stability [53]. In this study we have connected a synchronous generator with the DFIG wind turbine to analyze the effect of transients on the system with and without the inertial support.

For the synchronous generator to produce electricity and maintain constant voltage is supplied to the rotor of generator to produce magnetic flux that is essential for production of electricity. Current supplied to the synchronous generator excitation system is in alternating current AC fed from the generator output itself, in order to convert it to direct current DC it is passed through a thyristor-based rectifier and is then smoothen by passing through a filter. The level of DC can adjusted by firing signal of thyristor. The firing circuit of thyristor is controlled by voltage regulators which controls the excitation system of the generator. Current is directly fed to the generators rotor by way of slip rings which eliminates the problem of having another rotating machine [54]. A load step is added in the system to study transient condition and how the DFIG wind turbine react to any sudden increase in load.

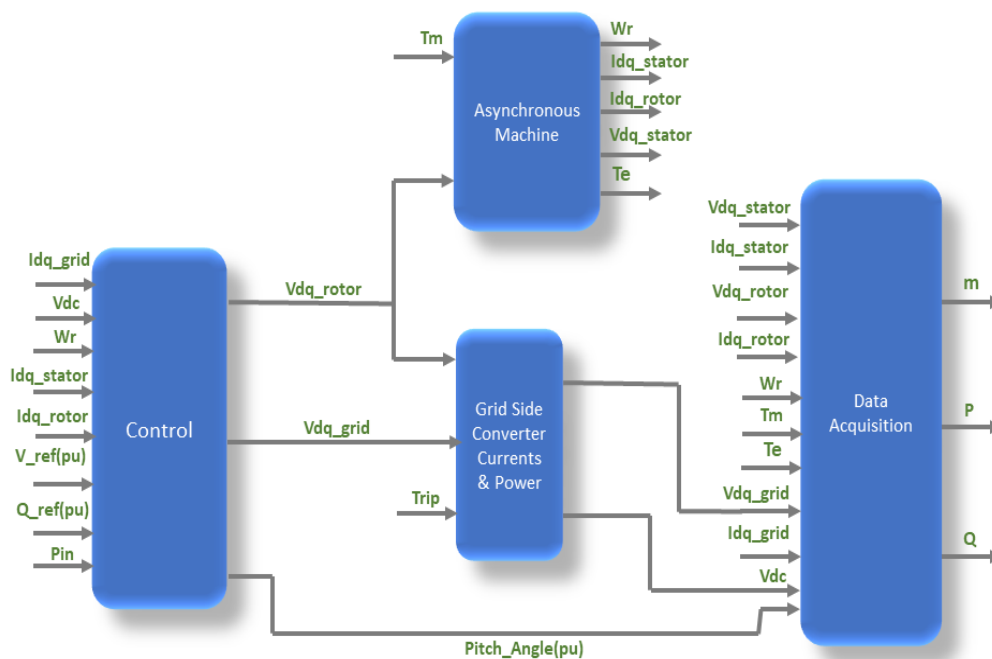

Figure.5 DFIG Wind Turbine Block Diagram

Electrical power system with multiple generators having low inertia would have to work efficiently and in coordinated way to keep the frequency steady. Present wind turbine technology with power electronic converter have inertia equal to zero connected to the grid are very like to behave unpredictably unstable and cause blackouts. Asynchronously generated energy for wind turbines mostly inject no inertia in power system because they are electronically decoupled from the grid [52].

Wind turbines can in principle emulate inertial behavior of conventional power plants and respond to the grid shocks by providing extra power through collaboration of power stored in flywheel of turbine and the solid-state power electronics. Kinetic energy accumulated in the rotational mass of wind turbines, extracted when system faces frequency deviation caused by the imbalance on power system, between load and generation [55].

Kinetic energy extracted to bring frequency back to optimal limit will reduce wind turbine rotor speed. Now accelerating the turbine to normal speed will absorb wind power which could be exported to the grid, reduction of 60% have been seen in ENERCON data. This post inertia recovery of wind turbine rotor speed could cause double dip in the system frequency, leading to triggering of protective relays and causing blackouts. To minimize frequency double dip risk system operators are re-evaluating synthetic inertia and plans 20% power reduction limit of turbine capacity during recovery of frequency [55].

Wind turbines are mostly implemented in rural and urban areas utilizing wind energy to generate electric power. When low wind speed then the voltage output from wind turbine after going through rectification is less, as this voltage is less compared to rated charging required voltage. This problem of less voltage is quite common in domestic regions cause wind speed is in range of 0 to 4m/s ultimately reducing efficiency to 20%. Therefore, buck boost converter is connected at the output terminal of wind turbines which boost the voltage produced at lower wind speeds to the required level of voltage. Buck boost converter is a cascaded DC DC converter connected in series with each other. When wind speed is low boost converter is activated and at higher speeds buck converter is activated to keep the voltage constant and keeping the system protected [56].

Voltage from wind turbine before being connected to grid is rectified then passed through a buck-boast converter to stabilize the voltage. Voltage on buck side is first converted to the direct current voltage and then through converter action buck or boosted to required voltage and is converted back to alternating current [56].

Optimizing the power output of wind turbine different control methods are used, generator speed control, pitch angle control and yaw control. Blade angle of turbine can be changed by using pitch control to attain certain rotor speeds by adjustment furl and stall. In stalling angle of attack is increased meaning flat side of the blade is further in the wind, furling angle of attack is decreased and flat side of the blade is perpendicular to the wind . It is most effective and proven way of limiting output power by varying the force applied on the blade aerodynamically at higher speeds of wind. On the other hand, Yaw control the horizontal axis rotation of turbine, making sure that turbine is constantly facing into the wind, because wind speed can vary very quickly misalign the turbine from facing into wind and costing losses in output power. The final type of control is done through electrical subsystems in which dynamic control of turbine is achieved by electronic converters which are connected at the terminal of generator [57]. All the different parameter of the system is taken to data acquisition for measuring and analysis purpose.

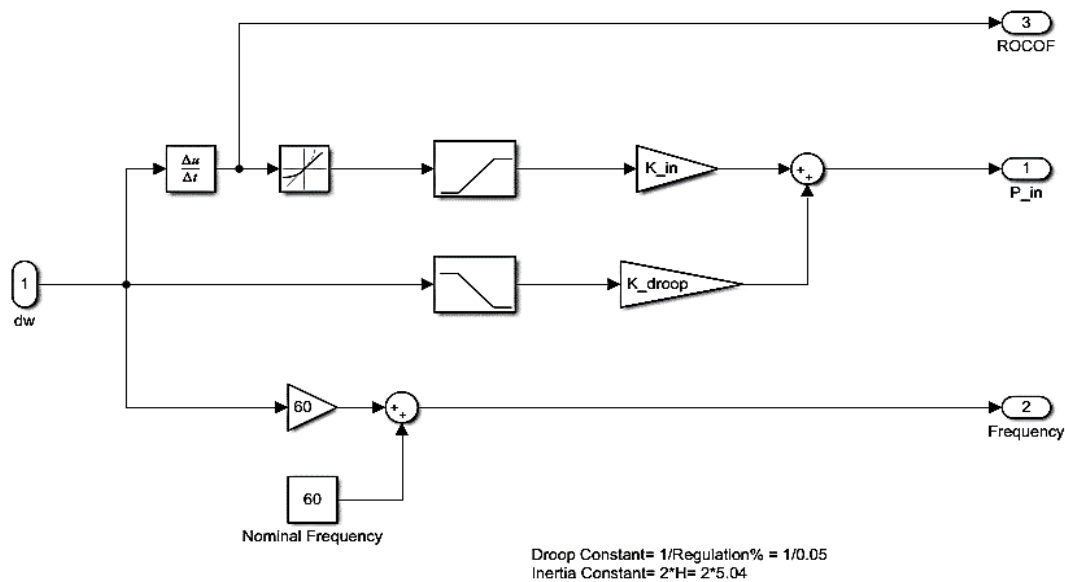

Figure 6: Inertial Loop

Virtual inertia is a feature used in renewable power systems with zero or low physical inertia, physical means having rotational inertia which in present power system is reducing rapidly as increase in renewable energy generation is integrated into the system. On one side integration of renewable is quite beneficial for the environment and long-term planning of power systems but on the other side it brings along some complications: varying power generation, weather constraints and having less or equal to zero inertial mass. Virtual inertia is

control technique aiming to control the DFIG wind turbine to regulate its output power when frequency deviation occurs due transient conditions. Rate of change of frequency ROCOF elucidates a reference signal to provide extra power, added with the normal reference provided by the maximum power tracking controller MPPT [58].

Inertial loop is an extra added loop in the power reference block which provide active power reference signal to the rotor

side of the converter. $2H(df/dt)$ is term introduced by auxiliary signal, H is inertial constant expressed in seconds representing the time active power is provided by the wind turbine when rotor of turbine is decelerated to from nominal speeds to zero to extract the kinetic energy accumulated in the rotating mass.

$$P_{auxref} = K_{droop}(f - f_0)$$

f_0 is nominal frequency 60Hz, Droop parameter for large conventional generator is in the range between 3 - 5%, depending on the type of generating unit [58].

This method is based on primary frequency controlled provided by the conventional generators. Droop controller are implemented on the wind farm level in place of applying to every single wind turbine. This shows that the signal generated from the controller is divided among the turbines in wind farms. Droop control loop reduces the torque accelerating rotor of the generator during the frequency dip. Combination of both droop controller and inertial controller is optimum for working of the DFIG wind turbines.

III. RESULTS AND DISCUSSIONS

1) Frequency Comparison

In figure 7, we are comparing the effect of virtual inertia compensation on the system frequency. There are two plot lines one is when inertial power required to bring frequency to stability. When inertial power is added the first harmonic of frequency drops to 59.31Hz while in the other condition frequency drops to 58.42Hz. Frequency in the latter condition recovers faster and with less harmonics. There is difference of 0.9Hz between the two. 0.9hz difference is large and if through this system frequency can improved then the system will quickly become stable and any unpredictable conditions can avoided.

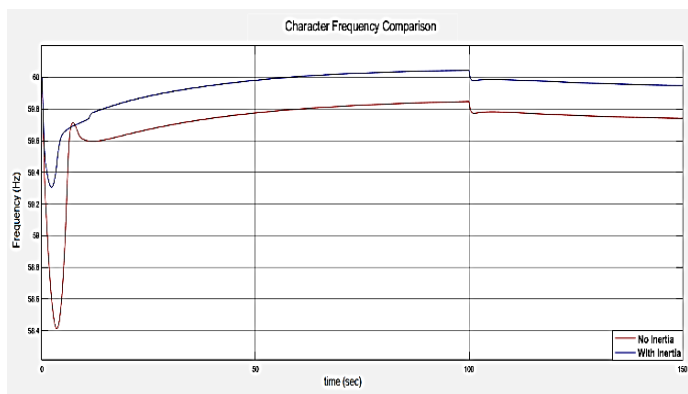

Figure 7: Frequency Comparison

2) Active Power of Wind Turbine

Active power of wind turbine is more when virtual inertia is added in the system. Virtual inertia addition makes the system slower and oscillatory due to which oscillation can be seen at the start of the operation. Additional active power during fault condition is drawn from the rotating masses. After the triggering of load step at 100sec mark active power has slightly increased again. The extra power produced by the

wind turbine slightly reduces the ROCOF giving more time to active governors to kick in and respond. Active Power comparison figure 8.

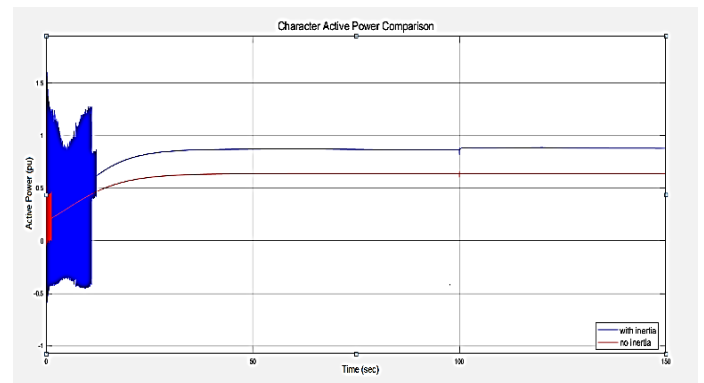

Figure 8: Active Power Comparison of Wind Turbine

3) Reactive Power of Wind Turbine

Generator utilization and generation of reactive power allows network operator to maintain the voltage stable throughout the power system. Reactive power plays crucial role in the stability of power system and flow of active power throughout the transmission system. For wind turbine to maintain the power factor equal to 1 reactive power supply in wind turbines is kept constant that is why reactive power management is essential. The fluctuation in the start of the plot is due to extraction of kinetic energy for addition of inertial power from the rotor of synchronous generator.

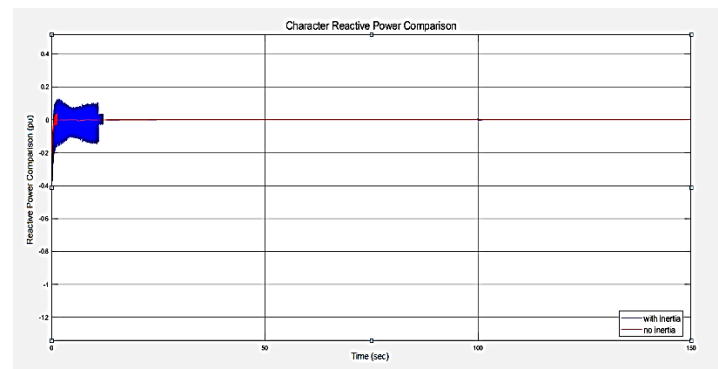

Figure 9: Reactive Power Comparison of Wind Turbine

4) Active Power of Generator

Generator power reference P_{ref} was set at 0.65pu. In figure 10 the blue plot after getting stabilized reaches the desired reference point earlier compared to red plot which was the system behavior when generator was not providing the extra inertial power for bringing the deviation to normal limits.

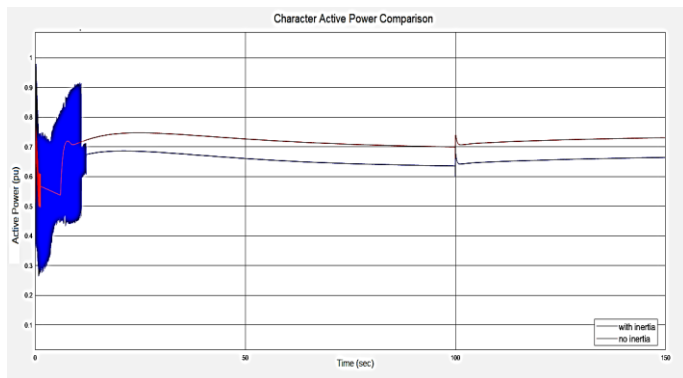

Figure 10: Active Power Comparison of Generator

5) Reactive Power of Generator

Loads connected to the system and load step at 100sec are purely resistive. We know that resistive load has no effect on the generator reactive power. That why in both the cases when load step is added they both react in the same way. Fluctuation in the start is due to generator startup which later on goes away when generator is stabilized.

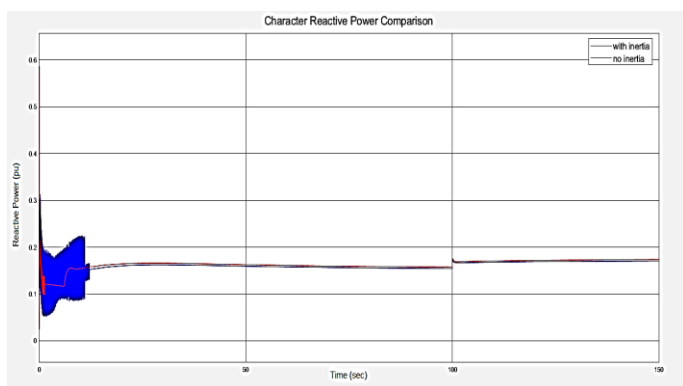

Figure 11: Reactive Power Comparison of Synchronous Generator

CONFLICT OF INTEREST

The author declares no conflict of interest.

CONCLUSION

This research focuses on alleviating the rotational mass and inertia related problems caused by increasing wind power integration by adding an inertial loop to compensate the impact of frequency deviations due to abnormal transient conditions. Reduced rotational inertia leads to faster frequency deviations and transient power exchanges over tielines in case of power fault. This may cause unexpected tripping of tielines due to automatic protection devices making the situation even critical. In this Study we found 0.9hz of frequency drop improvement from 58.42Hz to 59.31Hz with the addition of inertial loop in the system, which is quite a significant improvement for grid stability. Active power produced by wind turbine also increases reducing the Rate of change of frequency giving enough time to the rotating masses to respond to the transient situation. Active power or inertial power provided in this system is from a synchronous generator connected with grid. Reactive power of wind turbine is kept constant to keep the power factor unity.

These findings will prove extremely helpful in offsetting the drawbacks of greater wind energy addition to grid. The analysis needs to be further replicated with reduction in load and other transient conditions before being implemented in the grid.

REFERENCES

- [1] M. Asif, T. Muneer, "Energy supply, its demand and security issues for developed and emerging economies, Renewable and Sustainable Energy Reviews", Volume 11, Issue 7, 2007, Pages 1388-1413, ISSN 1364-0321.
- [2] E. Bompard, G. Fulli, M. Ardelean, and M. Masera, "It's a Bird, It's a Plane, It's a...Supergrid!: Evolution, Opportunities, and Critical Issues for Pan-European Transmission", IEEE Power and Energy Magazine, vol. 12, no. 2, pp. 40–50, Mar. 2014.
- [3] How to Solve Global Warming: It's the Energy Supply. Available Online At (<https://www.scientificamerican.com/article/how-to-solve-global-warming-its-the-energy-supply/>) [accessed 02-07-19]
- [4] 11 countries leading the charge on renewable energy (<https://www.climatecouncil.org.au/11-countries-leading-the-charge-on-renewable-energy/>) [accessed 02-07-19]
- [5] X. Liang, "Emerging Power Quality Challenges Due to Integration of Renewable Energy Sources," in IEEE Transactions on Industry Applications, vol. 53, no. 2, pp. 855-866, March-April 2017. Doi:10.1109/TIA.2016.2626253
- [6] Bird, L., Milligan, M., and Lew, D. Integrating Variable Renewable Energy: Challenges and Solutions. United States: N. p., 2013. Web. doi:10.2172/1097911.
- [7] Sandra Eriksson, Hans Bernhoff, Mats Leijon, Evaluation of different turbine concepts for wind power, Renewable and Sustainable Energy Reviews, Volume 12, Issue 5, 2008, Pages 1419-1434, ISSN 1364-0321 <https://doi.org/10.1016/j.rser.2006.05.017>.
- [8] M. F. M. Arani and E. F. El-Saadany, "Implementing Virtual Inertia in DFIG-Based Wind Power Generation," in IEEE Transactions on Power Systems, vol. 28, no. 2, pp. 1373-1384, May 2013. Doi: 10.1109/TPWRS.2012.2207972
- [9] Why wind energy? Available online at: (http://www.pmd.gov.pk/wind/Wind_Project_files/Page767.html) [Accessed 01-09-19]
- [10] Dong J, Xue G, Dong M, Xu X. Energy-saving power generation dispatching in China: regulations, pilot projects and policy recommendations—a review. Renew Sustain Energy Rev 2015;43:1285–300.
- [11] Saidur R, Rahim N, Islam M, Solangi K. Environmental impact of wind energy. Renew Sustain Energy Rev 2011;15:2423–30.
- [12] Kyoto Protocol to the United Nations framework convention on climate change. Available online at: (<http://unfccc.int/resource/docs/convkp/kpeng.pdf>); 1997 [accessed 01.10.19]
- [13] Cleaner and Cheaper: Using the clean air act to sharply reduce carbon pollution from existing power plants, delivering health, environmental, and economic benefits. Available online at: (<https://www.nrdc.org/file/3410/download?token=6c64p-xd>); 2014 [accessed 18.03.19]
- [14] Renewable Energy Target Scheme. Available online at: (<http://www.aph.gov.au/DocumentStore.ashx?id=17008e4b-e2f3-4ea3-9d53-fb3fb0cd4d85&subId=351098>); 2014 [accessed 17.11.19]
- [15] Renewables Global Status Report, REN21. Available online at: (http://www.ren21.net/Portals/0/documents/Resources/GSR2012_low%20res_FINAL.pdf); 2012 [accessed 01.05.19].
- [16] Mahzarnia M, Sheikholeslami A, Adabi J. A voltage stabilizer for a microgrid system with two types of distributed generation resources. IIUM Eng J 2013;14.

- [17] Chun Su. Line Effects of distribution system operations on voltage profiles in distribution grids connected wind power generation. *Proc IEEE Power Syst Technol* 2006;1-7.
- [18] Ausavanop O, Chaitusaney S. Coordination of dispatchable distributed generation and voltage control devices for improving voltage profile by Tabu Search. In: *Proc IEEE Elec Eng/Elect, Comp, Telecommun and Inform Technol Conf (ECTI-CON)*; 2011. p. 869-72.
- [19] Sekhar ASR, Vamsi Krishna K. Improvement of voltage profile of the hybrid power system connected to the grid. *Int J Eng Res Appl* 2012;2:87-93.
- [20] Bevrani H, Ghosh A, Ledwich G. Renewable energy sources and frequency regulation: survey and new perspectives. *Renew Power Generation, IET* 2010; 4: p. 438-57.
- [21] Dehghanpour K, Afsharnia S. Electrical demand side contribution to frequency control in power systems: a review on technical aspects. *Renew Sustain Energy Rev* 2015;41:1267-76.
- [22] Electricity Ten Year Statement (ETYS). Available online at (<http://www2.nationalgrid.com/UK/Industry-information/Future-of-Energy/Electricity-ten-year-statement/>); 2014 [accessed 11.05.19]
- [23] UK Future Energy Scenarios. Available online at (<http://www2.nationalgrid.com/WorkArea/DownloadAsset.aspx?Id=10451>); 2013 [accessed 11.05.19]
- [24] Jayawardena A., Meegahapola L., Perera S., Robinson D. Dynamic characteristics of a hybrid microgrid with inverter and non-inverter interfaced renewable energy sources: a case study. In: *Proceedings of IEEE Power Syst Technol (POWERCON)*; 2012. p. 1-6.
- [25] Ulbig A, Borsche TS, Andersson G. Impact of low rotational inertia on power system stability and operation. *arXiv preprint arXiv:1312.6435*; 2013.
- [26] Thresher R, Robinson M, Veers P. To capture the wind. *IEEE Power Energy Mag* 2007;5:34-46.
- [27] Mauricio JM, Marano A, Gómez-Expósito A, Martínez Ramos JL. Frequency regulation contribution through variable-speed wind energy conversion systems. *IEEE Trans Power Syst* 2009;24:173-80.
- [28] Revel G, Leon AE, Alonso DM, Moiola JL. Dynamics and stability analysis of a power system with a PMSG-based wind farm performing ancillary services. *IEEE Trans Circuits Syst I* 2014;61(7):2182-93.
- [29] Bianchi FD, De Battista H, Mantz RJ. *Wind turbine control systems: principles, modelling and gain scheduling design*. Springer Science & Business Media; 2006, ISBN: 978-1-84628-492-2.
- [30] Singh B, Sharmay S. Stand-alone wind energy conversion system with an asynchronous generator. *J Power Electr* 2010;10:538-47.
- [31] Lamchich MT, Lachguer N. *Matlab simulink as simulation tool for wind generation systems based on doubly fed induction machines*. INTECH Open Access Publisher; 2012.
- [32] Knudsen H, Nielsen JN. *Introduction to the modelling of wind turbines*. Wind Power in Power Systems, Second Edition:767-97; 2005.
- [33] Sun Y-z, Zhang Z-s, Li G-j, Lin J. Review on frequency control of power systems with wind power penetration. In: *Proceedings of IEEE Power Syst Technol Conference (POWERCON)*, 2010. p. 1-8.
- [34] Ekanayake J, Jenkins N. Comparison of the response of doubly fed and fixed-speed induction generator wind turbines to changes in network frequency. *IEEE Trans Power Syst Energy Convers* 2004;19:800-2.
- [35] Gonzalez-Longatt F., Chikuni E., Rashayi E. Effects of the synthetic inertia from wind power on the total system inertia after a frequency disturbance. In: *Proceedings of IEEE Ind Technol Conference (ICIT)*; 2013. p. 826-32.
- [36] Morren J, Pierik J, De Haan SW. Inertial response of variable speed wind turbines. *Electr Power Syst Res* 2006;76:980-7.
- [37] Wu L, Infield DG. Towards an assessment of power system frequency support from wind plant—modeling aggregate inertial response. *IEEE Trans Power Syst* 2013;28:2283-91.
- [38] Morren J, De Haan SW, Kling WL, Ferreira J. Wind turbines emulating inertia and supporting primary frequency control. *IEEE Trans Power Syst* 2006;21:433-4.
- [39] Zhang Z., Wang Y., Li H., Su X. Comparison of inertia control methods for DFIGbased wind turbines. in: *Proceedings of IEEE ECCE Asia Downunder (ECCE Asia)*; 2013. p. 960-4.
- [40] Wachtel S, Beekmann A. Contribution of wind energy converters with inertia emulation to frequency control and frequency stability in power systems. In: *Proceedings of the 8th international workshop on large scale integration of wind power into power systems as well as on offshore wind farms, Bremen, Germany*; 2009.
- [41] Ullah NR, Thiringer T, Karlsson D. Temporary primary frequency control support by variable speed wind turbines—potential and applications. *IEEE Trans Power Syst* 2008;23:601-12.
- [42] Hansen AD, Altin M, Margaris ID, Iov F, Tarnowski GC. Analysis of the short-term overproduction capability of variable speed wind turbines. *Renew Energy* 2014;68:326-36.
- [43] El Itani S., Annakkage U.D., Joos G. Short-term frequency support utilizing inertial response of DFIG wind turbines. In: *Proceedings of IEEE power and energy soc general meeting*; 2011. p. 1-8.
- [44] Keung P-K, Li P, Banakar H, Ooi BT. Kinetic energy of wind-turbine generators for system frequency support. *IEEE Power Syst* 2009;24:279-87.
- [45] Mishra S., Zarina P., Sekhar P. A novel controller for frequency regulation in a hybrid system with high PV penetration. In: *Proceedings of IEEE Power and Energy Soc General Meeting (PES)*; 2013. p. 1-5.
- [46] Josephine R, Suja S. Estimating PMSG wind turbines by inertia and droop control schemes with intelligent fuzzy controller in Indian. *Dev J Elect Eng Technol* 2014;9:1196-201.
- [47] Yao W., Lee K.Y. A control configuration of wind farm for load-following and frequency support by considering the inertia issue. In: *Proceedings of IEEE Power and Energy Soc General Meeting*; 2011. p. 1-6.
- [48] Eid BM, Rahim NA, Selvaraj J, El Khateb AH. Control methods and objectives for electronically coupled distributed energy resources in microgrids: a review. *IEEE Syst J* 2014:1-13.
- [49] Castro LM, Fuerte-Esquivel CR, Tovar-Hernández JH. Solution of power flow with automatic load-frequency control devices including wind farms. *IEEE Trans Power Syst* 2012;27:2186-95
- [50] Mansour Jalali (2011). *DFIG Based Wind Turbine Contribution to System Frequency Control*. UWSpace. <http://hdl.handle.net/10012/5730>
- [51] F. Blaabjerg, Z. Chen, R. Teodorescu and F. Iov, "Power Electronics in Wind Turbine Systems," 2006 CES/IEEE 5th International Power Electronics and Motion Control Conference, Shanghai, 2006, pp. 1-11. doi: 10.1109/IPEMC.2006.4777946
- [52] Johan Morren, Jan Pierik, Sjoerd W.H. de Haan, Inertial response of variable speed wind turbines, *Electric Power Systems Research*, Volume 76, Issue 11, 2006, Pages 980-987, ISSN 0378-7796, <https://doi.org/10.1016/j.epr.2005.12.002>.
- [53] M. F. M. Arani and E. F. El-Saadany, "Implementing Virtual Inertia in DFIG-Based Wind Power Generation," in *IEEE Transactions on Power Systems*, vol. 28, no. 2, pp. 1373-1384, May 2013. doi: 10.1109/TPWRS.2012.2207972
- [54] A. Kutsyk, M. Semeniuk, V. Tutka and T. Galianty, "A Pulse-Width Regulation of a Compound Excitation System for a Synchronous Generator," 2018 IEEE 3rd International Conference on Intelligent Energy and Power Systems (IEPS), Kharkiv, 2018, pp. 97-100. doi: 10.1109/IEPS.2018.8559510

- [55] Can Synthetic Inertia from Wind Power Stabilize Grids? Available online at:(<https://spectrum.ieee.org/energywise/energy/renewables/can-synthetic-inertia-stabilize-power-grids>);2016 [accessed 18.09.19]
- [56] Chandan, Shweta & Chayapathy, Venkataraman. (2014). Buck Boost Converter for Small Wind Turbine. IJLTEMAS. 3. 102-105.
- [57] Eduardo José Novaes Menezes, Alex Maurício Araújo, Nadège Sophie Bouchonneau da Silva, A review on wind turbine control and its associated methods, Journal of Cleaner Production, Volume 174, 2018, Pages 945-953, ISSN 0959-6526, <https://doi.org/10.1016/j.jclepro.2017.10.297>.
- [58] Margaris, Ioannis, et al. "Operation and Control of Wind Farms in Non-Interconnected Power Systems." Wind Farm-Impact in Power System and Alternatives to Improve the Integration. InTech, 2011, Doi: 10.5772/16532.

First A. Author Adnan Ismail is a postgraduate researcher at United States Pakistan Center for Advanced Studies in Energy at University of Engineering and Technology Peshawar, Pakistan. He is studying Electrical Energy System Engineering at MS level after doing his undergraduate degree in Electrical Engineering. His research interest include finding ways to integrate renewable energy in national grid and enhancing efficiency and stability of wind energy generation by utilizing virtual inertia techniques. This paper is a part of his Masters degree research studies.