

# Design of Hybrid Electromechanical Switch for Automatic Voltage Control of on Load Tap Changer Transformer

Uzair Khan<sup>1\*</sup>  and Dr. Abdul Basit<sup>2</sup>

<sup>1,2</sup>Center for Advanced Studies in Energy (CAS-E), Department of Electrical Energy System, University of Engineering and Technology Peshawar, Pakistan

uxairkhan25@gmail.com<sup>1</sup>, abdul.basit@uetpeshawar.edu.pk<sup>2</sup>

Received: 25 February, Revised: 01 March, Accepted: 18 March

**Abstract**— On Load tap changer OLTC transformer having electromechanical hybrid switch, is used to regulate voltage level by changing the taps without arcing which cause increase or decrease in voltage level in a very efficient and coherent manner depending upon the requirement of the system. Mostly mechanical type of On Load tap Changer is widely used for control voltage in distributed networks. Mechanical On Load Tap Changer has some disadvantages during tap changing process like causing arc, slow switching, high malfunction rate and require manpower. In mechanical switches wear and tear occurs due to tap changing due to the arcing phenomenon. Besides these drawbacks, there are also some advantages of mechanical OLTC such as low on-steady losses and high overload capacity. Due to fluctuations in voltage level of smart grid a hybrid power electronic assisted mechanical On Load Tap Changer transformer is designed. In this research paper a hybrid Switch is proposed using the advantages of mechanical as well as electronic bidirectional switches for automatic tap changing of OLTC transformer. The electronic OLTC uses semiconductor namely IGBT as a bidirectional switch. By using electromechanical switch the taps changing process will be arc less and there will be low On-state losses and high over load capacity. This will provide automatic, arc free tap change and long lifetime.

**Keywords**— Hybrid switch, On-load tap changer, Bi-directional switch, No-load switch, Auto-transformer.

## I. INTRODUCTION

Various voltage levels are normally used to operate electrical power systems. The transformer that was invented 19<sup>th</sup> century and also started operation which became the strong foundation of today's modern era. In today's modern technology also the grid power transformers are an essential component of the system in today's increasingly complex power system, and research in this area has never stopped. Power system design and operation have been largely

concerned with power quality. This challenge is growing even more serious as smart networks with unstable sources of renewable energy including wind turbines and solar panels become more prevalent. A voltage regulator, reactive power compensation, large-scale energy storage, etc are only a few of the actions that need to stabilize power transmission and develop the excellence of power. The most popular method for voltage regulation in modern power system design is to modify the transformer voltage using a tap changer. The on-load tap-changer is equipment being used to modify the voltage's amplitude. Due to its features of a wide voltage regulation scope and no breakdown of power during the voltage regulation process, the OLTC has incomparable benefits over the no-load voltage controlling transformer in terms of improving power quality and assuring the effective operation of the power system. Technology currently makes extensive use of mechanical on-load tap changing devices. Technology development has made life for us simpler and easier. To fix the flaw in conventional OLTC, power electronics tap change also known as PE-OLTC, is a concept that has been put forth.

## II. LITERATURE REVIEW

On-load tap-changer device is incorporated into the conventional distribution transformer on account of the characteristics of significant voltage drop/loss, greater line loss, and reduced power superiority in power supply and distribution networks to attain the best voltage regulation in a power grid[1]. In this chapter we will discuss the different types of OLTC's which are used for the regulating and controlling voltage. OLTCs are the important components of distribution system. To control the amplitude of the in-phase voltage, a device called an oltc is employed. To contrast it with the no-load voltage regulating transformer, the OLTC has the features of a wide voltage regulation range and with no power break-down situation during the voltage regulation process, which has unrivalled benefits in enhancing the quality of electricity and ensuring the financial process in the power network[2], [3]. Nowadays, mechanical oltc devices are widely used in technology. However, this classic on-load tapping approach

still has several expected flaws, such as complicated topology, abnormal arcs, and sluggish reactions[4]. Using the rapidly evolving power - electronic technology to build the tap changer of the power transformer and enhance the efficiency of conventional tap-changers is an obvious innovation in the coming years in order to advance the design and making progress performance of the OLTC transformer and become familiar with the latest basic needs of electric grid progress[5], [6].

#### A. Basic Principle Of OLTC

Step less voltage and step-voltage regulation are two types of transformer voltage regulation that, in general, modify the transformer ratio. The variation in the transformer's winding taps is known as step voltage regulation. In areas with a lower voltage levels and insufficient capacity, step less voltage control is typically employed. Transformer voltage regulation includes: OLTC and OPTC (Off-Power Tap Changer)[7]. When there is a systemic power outage, OPTC disconnects the main side from the grid and modifies the voltage ratio of the transformer by adjusting the voltage of the secondary winding. Research shows that it is increasingly overtaken by on-load voltage regulation and is only useful in situations where electricity must be switched off for a brief period of time with no or little voltage adjustment [8], [9]. OLTC voltage regulation refers to the installation of taps on specific transformer windings and the execution of the tap change will be done when the load is coupled to the secondary side. To vary the ratio of winding turns, a section of the winding is disconnected or rejoined during the tap change procedure. Voltage control is finally achieved by changing the ratio, which also alters the output voltage[10].

#### B. Types Of OLTC

Such devices may be broadly categorized into three varieties based on the properties of their taps: mechanical or manual tap changers, hybrid (Electro-mechanical) tap changers and pure power electronic tap changers. Each of these have their own advantages and limitations[12].

##### 1) Mechanical OLTC

In early periods mechanical tap changers were used mainly for voltage regulations. The low speed of switching and high losses during tap changing process originated from mechanical tap changer. Although mechanical oltc devices are already widely utilized in systems, but they still have several deep problems, such as complicated structure, abnormal arcs, sluggish responses, etc.[6], [13].

##### *Working Mechanism of Mechanical OLTC*

The operating order is mechanically synchronized to ensure that each contact or tap consistently performs in the proper order. The tap changer and transformer may sustain serious harm in the event that the operational mechanism fails. The mechanical taps are situated on a regulating winding that is linked in series to the main winding through a reversing switch and is housed inside the main transformer tank. Moving taps that uses stepping task from one connection to another in order to attach or remove turns to the regulating winding are used to

increase or reduce voltage. The default setting is neutral, which prevents the OLTC from changing the voltage or connecting the tap windings to the circuit in the system. The only occasion the reversing switch is not carrying current is when it is in the neutral position[3], [14].

##### 2) Hybrid OLTC

The concept of hybrid power electronic assisted switch has been proposed for power transformer due to its low cost and arc-free switching capabilities. To eliminate the limitations and drawbacks of mechanical OLTC, electronic switch for tap changers were introduced due to its high speed, low maintenance cost and arc-free advantages. A hybrid switch, power electronic assisted switch is obtained to combine as one, having the properties and benefits of pure power electronic and manual switch[12]. For correct size of the hybrid electro mechanical OLTC and its security system, the utmost voltage level across the electronic switch must be determined in every operational condition of the transformer. Electronic assisted OLTC are designed for fast response and hence avoid high short-circuit currents during switching operation. Mostly mechanical type OLTC's have been added by electronic thyristor based on load tap changers in low voltage applications because of their economical and robusting properties. However for medium line voltage system this addition does not work. On load tap changers OLTC power transformers have mechanical switches which have drawbacks such as low switching, arcing and wear tear[4], [6].

##### *Working Mechanism of Hybrid OLTC*

This type of OLTC is composed of mechanical and some part is composed of electrical. The OLTC mechanism is realized through a mix of no-load switches and a single hybrid switch. A mechanical component known as a no-load switch opens or closes in the absence of a load. It does not experience any arcing when it is being operated at no load. The concept comes from voltage regulators of the "diverter switch" variety. In this case, the taps are selected using two movable no-load switches or "selector switches", and the tap change procedure and steady-state load current are carried out by a mechanical "diverter" switch[10].

##### 3) Fully Power Electronic (PE-OLTC)

OLTC's of the power electronic switch type that have accelerated on-load voltage regulation's reaction time, have been the subject of research since the nineties. Switching loss is minimized, switching speed is fast and frequent switching are benefits of this technique[9]. Full power electronic switches were introduced to improve performance of OLTC power transformer, but high cost of semiconductors components were imposing limitation for its application. The concept of power electronic switch OLTC has been proposed for power transformer due to its arc-free switching capabilities. Use of semiconductor which have no arcing issues, is common in PE switches [16], [17].

##### *Working Mechanism of Fully power electronic OLTC*

In order to enhance the efficiency of the system, PE devices are included in the circuit to avoid this issue[18]. When a load's output voltage varies, the "voltage detecting device" linked to

the output node detects this variation and sends the information to a comparator[19]. Comparator is used to match up a computable quantity that has a reference or standard for example two voltages or currents. It produces a digital signal that displays the outcomes. As a result, it analyzes voltage and activates the isolating device in order to switch-ON the TRIAC semiconductor device. This semiconductor device then modifies the taps in accordance with the output voltage which is a fully automated process.[20].

### C. Comparison of Mechanical & Automatic OLTC

Comparison is the best and easiest way to differentiate between two quantities or concepts. The comparison of mechanical manual and hybrid OLTC is discussed in this part[21].

TABLE I. COMPARISON BETWEEN MECHANICAL & HYBRID TYPE OLTC

Mechanical Tap Changer	Hybrid OLTC
Mechanical/manual is used.	Triac switch is used.
Arcing occurs while tapping.	Arc-less tapping.
Maintenance cost is high.	Maintenance cost is low.
Delayed switching.	Quick Switching.
Insufficient stability.	Enhanced stability.

### D. Voltage Regulation Through OLTC Transformer

Series compensation and shunt compensation techniques are employed for achieving voltage compensation.

- Leading current or lagging current must be introduced into the grid in order to adjust the voltage in the shunt compensation method.
- To adjust the line impedance, series compensation involves adding of voltage otherwise connecting in series a reactive device with the line.

Shunt compensation is based on the idea that injecting a lagging current raises voltage while injecting a leading current lowers voltage at that point. From equation 1, it is clear that the the voltage drop and reactive power along the line are directly related. Shunt compensation uses devices like switched capacitor or inductor banks, variable current sources controlled by thyristors, and thyristor-switched capacitors. Series compensation on the other hand, works by introducing a voltage in series that makes up for the voltage loss along the line Vline. For instance, on and off load tap changing transformers, self-commutated switches such as the unified-power flow controller UPFC. By changing the transformer taps, an output varying voltage can be produced for a input fixed voltage by modifying the ratio of voltage of the transformer windings. Tap changers must be able to swap taps when on-load in order to guarantee uninterrupted energy supply in future distribution networks with massive injections of power.

## III. DESIGN OF THE PROPOSED SWITCH

### A. Block Diagram Of Hybrid Switch

Figure 1 shows the block diagram of hybrid switch in OLTC system. The below block diagram is composed of a mechanical switch and two bidirectional switches which are connected to No-load switches. A mechanical switch that opens or closes when there is no load is known as a no-load switch. It does not experience any arcing when it is used in no-load conditions. No load switches then making connecting with the hybrid switch using AC supply. Load shouldn't be ignored because it has a significant impact on the whole system and where  $Z_{Line}$  is the impedance of the line. The hybrid switch consists of two IGBT bidirectional semiconductor switches and one mechanical switch which is given in figure 1.

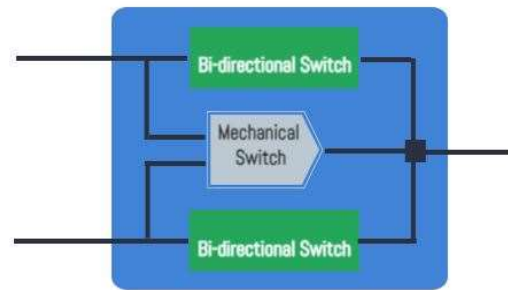

Figure 1. Hybrid Switch with two bidirectional IGBT switches and a mechanical switch.

### B. OLTC Circuit Design Having No-Load Switches & A Hybrid Switch.

On the basis of the current and voltage ratings of the transformer and tap switches, as well as the isolation requirements various OLTC topologies using traditional winding transformers and autotransformers were examined. The OLTC topology with an autotransformer containing taps on the load side was chosen. The preference is due to the most favorable condition of component power ratings, copper savings and isolation requirements. To know the OLTC mechanism, a pair of no-load switches and a single hybrid switch is used. Actually, no load is a type of mechanical switch which turns on and off when there is no load. There will be negligible arcing if we operate it under no load condition.

The autotransformer's taps are each connected to a no-load switch in figure 2 and then no-load switches are in turn connected to one another alternately. The hybrid switch is in turn linked in series with the taps of autotransformer. The tap-changing process is done by bidirectional electronic switches whereas mechanical switch operates the load current in steady state.

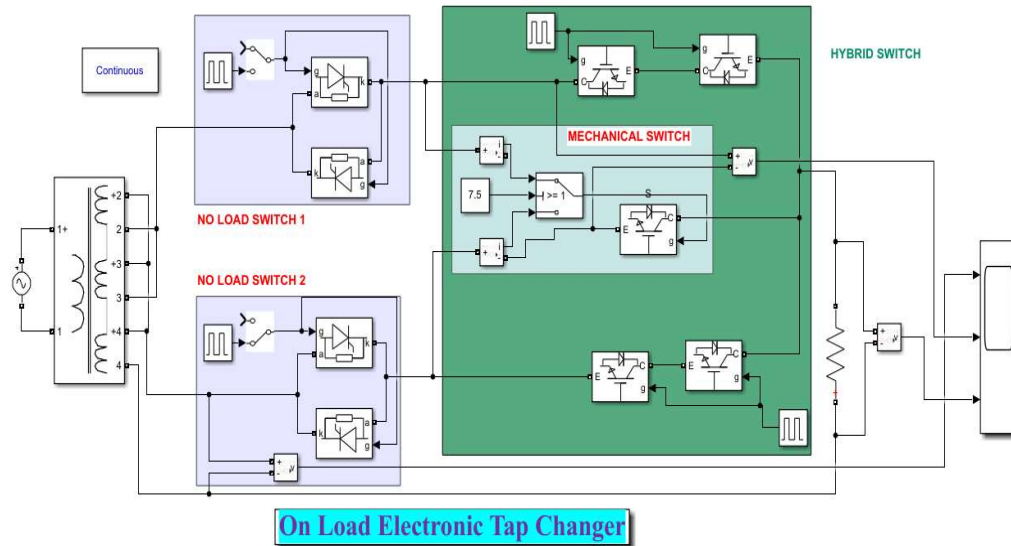

Figure 2. MATLAB Simulink model

At a time just one of the no load switches will be closed. This is done just to prevent the occurring of short circuits between the taps. Taps can be changed in only one step. By one step, it is meant that tap changing can be done only to tap 1 or tap 3 from tap 2 in ON condition. It also ensures that the maximum voltage of hybrid switch is equivalent to the voltage of just one tap. When switching from one tap to another during the hybrid switch is done, for example switching from no-load 1 to no-load 2, it is done through the seven step mechanism shown in Table II. In Table II, the switches ON and OFF states are shown by the numbers 1 and 0 respectively. Considering the position of Mechanical switch, when it is connected to bidirectional switch then it is specified by 1.

TABLE I  
SEVEN STEPS COMMUTATION BETWEEN THE CONTACTS

Step No.	No-Load Switch		HYBRID SWITCH		
	NL1	NL2	Bidirectional switch 1 (BS1)	Bidirectional switch 2 (BS2)	M
0	1	0	0	1	0
1	1	1	0	1	0
2	1	1	1	1	0
3	1	1	1	0	0
4	1	1	0	0	1
5	1	1	0	1	1
6	1	1	0	1	0
7	0	1	0	1	0

In step 1, the no load switch that is near to the new tap position i.e NL2, is switched ON while mechanical switch (M) and no-load switch 1 (NL1) carry the load current. Next steps are step 2 and step 3 in which bidirectional switch (BS1) is activated and the current commutates from switch BS1 to

mechanical switch M with no arcing happening. Current commutation takes place between the two semiconductor bidirectional switches BS1 and BS2 in step 4. While the commutation of current occurs back from bidirectional switch 2 (BS2) to mechanical switch (M) in steps 5 and 6. The series-connected electronic switches BS1/BS2 must always be in the OFF position in order for the no-load switches NL1/NL2, to change their states. Due to low ratings of voltage of the bidirectional electronic switches and simple operation of no load switches, causing generally low cost of OLTC system.

#### IV. SIMULATIONS AND RESULTS

This chapter simulates the system design covered in the earlier chapter. Figure 3, which was created using MATLAB's Simulink, displays the entire model of the OLTC mechanism's hybrid switch. Also a detailed discussion is made of the outcomes obtained from these simulations. The hybrid switch and no-load switches make up the majority of the model. The transformer used in the model is autotransformer in order to consume less windings and low cost. The no-load switch has a pulse generator and two thyristor switches. The pulse generators give signals to thyristors in order to activate them. The hybrid switch is the core part of the model because most area of this research work is related to it. The green part of the below model shows the whole hybrid switch which is composed of two parallel bidirectional switches and a mechanical switch. An impedance load is also connected across the hybrid switch. The system is first simulated under ideal operating settings, followed by explanations of fault generating scenarios and simulations of those faulty conditions. The outcomes of these simulations are then all examined.

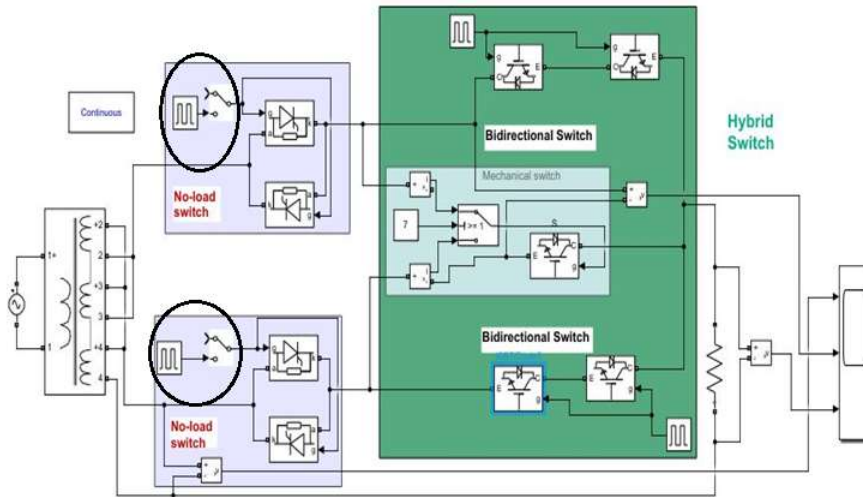

Figure 3. MATLAB model of Hybrid switch in OLTC mechanism

OLTC system is designed to make sure that the flow of voltage should be smooth without any fluctuations and instability. Power transformers only have one moving component which is the OLTC system, making them extremely prone to failures. Majority of the failures arises from arcing leading to abnormal arcing energies. It has high failure rate that's why it accounts for greater than 20 percent of all transformer failures and the main reason for this is its complex structure and demand of efficient electrical performance, therefore it is crucial to monitor how things are running. Perform an online diagnosis, and then take safety precautions to prevent mishaps.

#### A. OLTC System With No Fault- Simulation And Results

The on-load tap-changer is utilized extensively because it is a key piece of equipment for regulating voltage in the power system. It is used to automatically adjust taps and controls voltage. In order to lower the loss while the system is operating and also for modification in transformation ratio oltc is used in almost every corner of the world. The no fault scenario in the above designed model can be detected by the uniform and regular flow of voltage in normal operation. Usually the pulse signals of the no-load switches are off when there is no fault and the system is working under normal condition. As the system functionality is normal under no-fault condition hence the no-load switches are not changing the taps automatically. The pulse signals are not connected to the no-load switch. No-load switches are attached to the autotransformer and these switches are then connected to bidirectional IGBT switches of hybrid switch. The purpose of mechanical switch is to make certain in order to reduce steady state losses and high overload capacity while that of bidirectional switch is to eliminate arcing during tap changing. Therefore hybrid switch provides multifunctional advantages to the system and is the future of power system.

The above designed circuit is simulated in normal condition, with both the pulse generators of the no-load

switches in off state as shown inside the circles in figure 3. As told earlier that in normal or no-fault condition the voltage supply is uniform and stable. As shown in figure 4 the input supply is uniform and there is no interruption in the supply of voltage at this stage. The operation of the system is continuous without any fault and unsuitable state. Most of the time when there is no interrupt in the voltage level of hybrid switch, there is no problem in the supply of voltage to system.

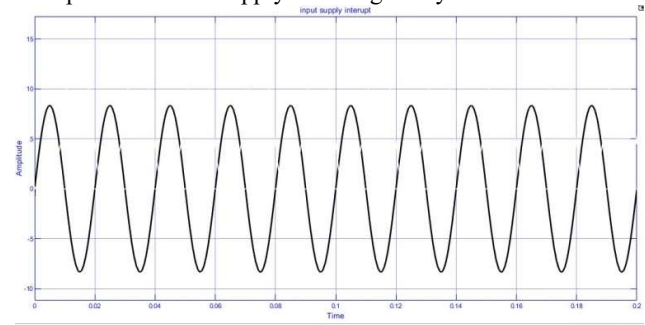

Figure 4. Input voltage supply

#### B. Fault Scenario Of OLTC System- Simulation And Results

Research shows that the primary issue with the OLTC distribution generator is mechanical failure, mechanical movement causes mechanical wear and add up to a higher risk of failure than solid-state devices. If the mechanical mechanism in an OLTC would break down, it could cause a power failure on the grid. It is observed that the rate of failure grows in direct proportion as the voltage regulation rises with time. Whenever fault occurs, it creates disturbance in the uniform operation of the system that effects the operation of the system causing various problems for different parts of the OLTC system such as arcing and wear & tear. During the process of changing the tap, the surface of contact will be degraded by arcing, which may impact the contacts' lifespan and also may increase the chance of arcing in future.

Typically, the central part of power transformers is the on load tap changers that can be perform a variety of helpful and proficient tasks. As a result, It is believed that a power transformer's sole moving part is a tap changer. Utilizing a tap changer, the mechanism varies the output voltage by considering how many turns to make in the windings. Research on power transformers has revealed that the on-load tap changer is the primary factor for defects in power transformer. Majority of faults occurring in oltc are due to the insulation and deterioration and contacts failure inside it may be also the main culprit for the fault. Additionally, these faults can lead to the overall failure of the transformer components. Fault in the oltc of a power system can be detected by the non-uniform and distorted signals of input voltage supply, mechanical switch interrupt and output voltage as shown in figure 5.

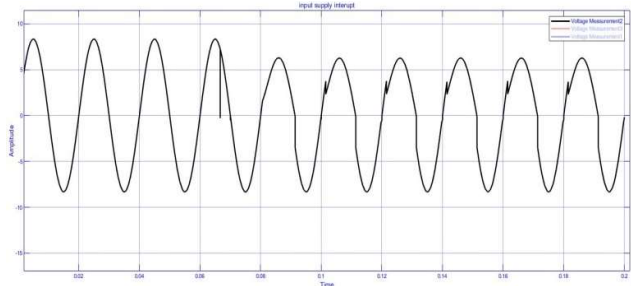

Figure 5. Non-uniform and Distorted signals during fault condition

Due to fluctuations in the input voltage supply of the OLTC transformer the operation and parts of the system can be badly affected during this condition, but the main purpose of Hybrid

switch is that while changing of taps, the load current should not be stopped so that the operation and functionality of the power system must not be affected. Hybrid switch consist of electronic IGBT switches that's changes the taps automatically without arcing hence reducing the risk of wear & tear of the tap contacts of OLTC.

When fault scenario is detected by the no-load switches of the OLTC of power transformer, the pulse signals of both the no-load selector switches are turned on to activate the no-load switches for tap changing process as shown in figure 6. The two bidirectional switches are connected to no-load selector switches. The bidirectional IGBT switches are turned on simultaneously and not at a same time in order to prevent short circuit. In order to transmit the AC load current, one switch will conduct as a forward switch and the other as a reverse switch but the primary job is that IGBT must be always active so that there is no stoppage of current. The hybrid switch is designed to maintain the level of voltage whenever voltage fluctuations occur through taps shifting of the OLTC power transformer. And the green area shown in figure 6 is hybrid switch which consists of two pairs of bidirectional IGBT switches and a single mechanical switch. The two pairs of bidirectional IGBT switches are linked with the mechanical switch and then connected with no-load selector switches for tap changing process. When the fault is detected by non-uniform and distorted input voltage waveform, the pulse signals of the no-load switches are activated as shown inside the circles in figure 6.

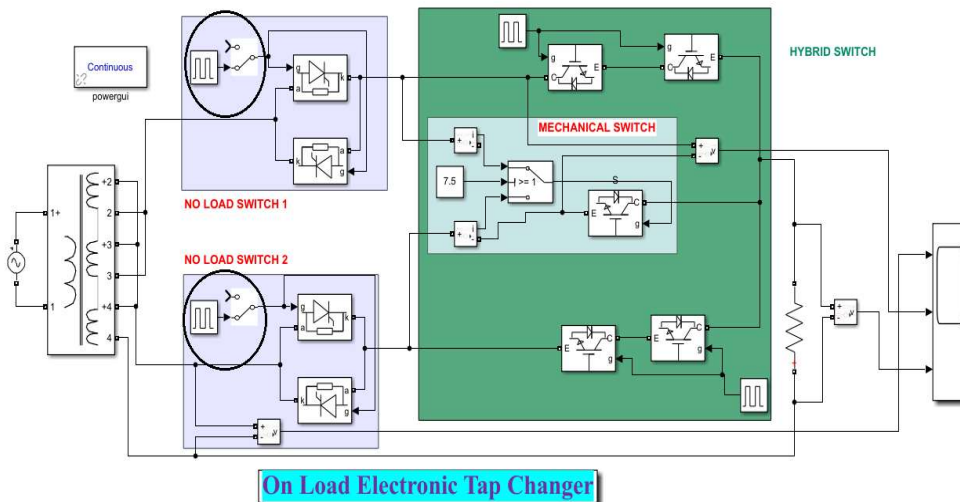

Figure 6. Pulse signals of the no-load switches are turned-on.

Since the system is now operating in fault-free, oscillation-free and in normal conditions therefore pure sinusoidal voltage waves were produced, as shown in Figure 7.

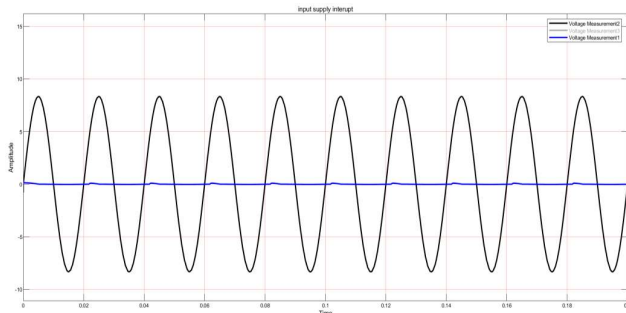

Figure 7. Uniform and sinusoidal waveform of voltage after no-load switches are turned on.

## CONCLUSION

Due to the widespread combination of renewable energy sources such as PV etc, voltage oscillations and overvoltage could be seen in the distribution network. To address this issue, a new topology for an oltc auto-transformer with the assistance of power electronic is put forth for distribution network. The OLTC taps exhibit various benefits and for this purpose a hybrid switch was created by using a collection of no-load switches, a single mechanical switch and two semiconductor electronic switches. The oltc utilizes a mechanical switch and an electronic switch (which makes up an hybrid switch) in tap changing process in order to ease steady state losses and avoid arcing of taps and voltage spikes. Because of this, OLTC can operate for a very long time even when exposed to frequent voltage swings. By inclusion of bidirectional switch IGBT switch it is made sure to perform the tap changing process in a convenient way by opting out the consideration of an open or short circuit. It is also discussed that how to manipulate voltage by using conventional mechanical oltc, power electronic oltc and mechanically upgraded oltc approach. The expenses and arcing that is caused during tap changing process of OLTC is decreased due to advancements in power electronics technologies.

## REFERENCES

- [1] J. Tu and Y. Mi, "Research on Transformer Fast OLTC System," *J. Phys. Conf. Ser.*, vol. 1187, p. 022002, Apr. 2019, doi: 10.1088/1742-6596/1187/2/022002.
- [2] H. Zhou, X. Yan, and G. Liu, "A review on voltage control using on-load voltage transformer for the power grid," *IOP Conf. Ser. Earth Environ. Sci.*, vol. 252, p. 032144, Jul. 2019, doi: 10.1088/1755-1315/252/3/032144.
- [3] J. Sanchez and M. Banovic, "Basics of Power Transformers What are the basic transformation principles and essential transformer parts?," 2014.
- [4] N. Chen and L. Jonsson, "A new Hybrid power electronics on-load tap changer for power transformer," vol. 2015, pp. 1030–1037, May 2015, doi: 10.1109/APEC.2015.7104475.
- [5] J. M. Canales, D. Serrano-Jiménez, M. Barrenetxea, J. A. Barrera, A. Goikoetxea, and J. Anzola, "Electronic on Load Tap Changer Transformer for DC Electrical Railway Power Supply Systems. 2019, p. 4. doi: 10.1109/VPPC46532.2019.8952415.
- [6] G. R. Chandra Mouli, P. Bauer, T. Wijekoon, A. Panosyan, and E.-M. Baerthlein, "Design of a Power Electronic Assisted OLTC for Grid Voltage Regulation," *IEEE Trans. Power Deliv.*, vol. 30, pp. 1–1, Jan. 2014, doi: 10.1109/TPWRD.2014.2371539.
- [7] D. Das, D. Divan, and R. G. Harley, "Power Flow Control in Networks Using Controllable Network Transformers," *Power Electron. IEEE Trans. On*, vol. 25, pp. 1753–1760, Aug. 2010, doi: 10.1109/TPEL.2010.2042076.
- [8] P. Mohite and C. Thorat, "A review of zero-voltage switching and its importance to voltage regulation. 2017, p. 2906. doi: 10.1109/ICPCSI.2017.8392254.
- [9] S. Guan et al., "Research on a new type of on-load automatic voltage regulation technology," 2017 IEEE 2nd Adv. Inf. Technol. Electron. Autom. Control Conf. IAEAC, pp. 2541–2544, 2017.
- [10] D. Rogers and T. Green, "A hybrid diverter design for distribution level on-load tap changers. 2010, p. 1500. doi: 10.1109/ECCE.2010.5618245.
- [11] G. Ram, V. Prasanth, P. Bauer, and E.-M. Bärthlein, "Comparative analysis of on-load tap changing (OLTC) transformer topologies," in 2014 16th International Power Electronics and Motion Control Conference and Exposition, 2014, pp. 918–923. doi: 10.1109/EPEPEMC.2014.6980624.
- [12] D. D. I. Dohnal, O.-Lo. Tap-Changers, fOr pOwer TransfOrmers, M. K. Base, O.-Lo. Tap-Changers, and fOr pOwer TransfOrmers, "On-Load Tap-Changers for Power Transformers," 2006.
- [13] D. Gao, Q. Lu, and J. Luo, "A new scheme for on-load tap-changer of transformers," *Proc. Int. Conf. Power Syst. Technol.*, vol. 2, pp. 1016–1020 vol.2, 2002.
- [14] B. Poulin, R. M. D. Vecchio, P. T. Feghali, R. Ahuja, and D. M. Shah, "Transformer Design Principles: With Applications to Core-Form Power Transformers," 2001.
- [15] S. García, J. Rodríguez, J. A. Jardini, J. Vaquero, A. Segura, and P. Cid, "Feasibility of Electronic Tap-Changing Stabilizers for Medium Voltage Lines—Precedents and New Configurations," *Power Deliv. IEEE Trans. On*, vol. 24, pp. 1490–1503, Aug. 2009, doi: 10.1109/TPWRD.2009.2021032.
- [16] J. Vaquero, S. Garcia, J. Rodriguez, R. Vela Garcia, S. Fernandez, and C. Olay, "Electronic Tap-Changing Stabilizers for Medium-Voltage Lines Optimum Balanced Circuit," *Power Deliv. IEEE Trans. On*, vol. 27, pp. 1909–1918, Oct. 2012, doi: 10.1109/TPWRD.2012.2198673.
- [17] S. Rao and B. Subramanyeswar, "Fine Voltage Control Using Oltc by Static Tap Change Mechanism," 2012.
- [18] J. Faiz and B. Siahkollah, "Electronic Tap-changer for Distribution Transformers, vol. 2. 2011. doi: 10.1007/978-3-642-19911-0.
- [19] G. H. Cooke and K. T. Williams, "Thyristor assisted on-load tap changers for transformers. 1990, p. 131.
- [20] J. H. Harlow, "Electric Power Transformer Engineering," *Electr. Insul. Mag. IEEE*, vol. 20, pp. 64–64, Jun. 2004, doi: 10.1109/MEL.2004.1307095.
- [21] V. Bugade, "Automatic Voltage Control of Load using on Load Tap Changer," *Int. J. Res. Appl. Sci. Eng. Technol.*, vol. 6, pp. 3158–3162, Mar. 2018, doi: 10.22214/ijraset.2018.3681.

**Uzair Khan** and Dr Abdul Basit "Design of hybrid electromechanical switch for automatic voltage control of On Load Tap Changer Transformer" *International Journal of Engineering Works*.

## How to cite this article:

Uzair Khan, Dr. Abdul Basit "Design of Hybrid Electromechanical Switch for Automatic Voltage Control of on Load Tap Changer Transformer" *International Journal of Engineering Works*, Vol. 10, Issue 03, PP. 22-28, March 2023. <https://doi.org/10.34259/ijew.23.10032228>.

