



# Designing and Analysis of Single Stage and Two Stage PV Inverter Connected to Weak Grid System

Naveed Malik<sup>1</sup>, Sami Ullah<sup>2</sup>, Amir Khan<sup>3</sup>, Farhan Ullah<sup>4</sup>

<sup>1,2,3,4</sup> Department of Electrical Energy System Engineering, US-Pakistan Center for Advanced Studies in Energy (USPCAS-E), UET Peshawar

[engrmaalikuet@gmail.com](mailto:engrmaalikuet@gmail.com)<sup>1</sup>, [samiullahkhan4191@gmail.com](mailto:samiullahkhan4191@gmail.com)<sup>2</sup>, [amirkaahn@gmail.com](mailto:amirkaahn@gmail.com)<sup>3</sup>, [farhan.ullah58@gmail.com](mailto:farhan.ullah58@gmail.com)<sup>4</sup>

Received: 05 October, Revised: 13 October, Accepted: 17 October

**Abstract**— In this research paper design, analysis and comparison of single stage and two stages Photovoltaic inverter connected to weak grid system is executed in terms of their maximum power point tracking, DC link voltage regulation, power factor and overall efficiency. Majority of the commercial and industrial loads are inductive in nature and result in a very low lagging power factor. However renewable energy sources have no reactive power generation and lagging power factor results in a weak grid system. For this purpose control mechanism comprises of three objectives is proposed in this research paper. These objectives are to obtain highest amount of power from photovoltaic array, the power must be deliver from photovoltaic array into the utility grid at unity power factor and to maintain desired voltage at the input of the inverter. In order to achieve these objectives nonlinear control mechanism of Photovoltaic inverter connected to weak grid system is established and implemented based on accurate mathematical modeling and by using Backstepping technique and Lyapunov Stability analysis. PI controller is used for the purpose to maintain desired voltage at input of the inverter according to the requirement of inverter. Both single stage and two stage models are developed and simulated in Simulink/Matlab environment.

**Keywords**— Photovoltaic (PV), Maximum power point tracking (MPPT), Power factor control (PFC)

## I. INTRODUCTION

There is a rapid increase in population and industrialization of the world and due to this increase demand for electrical energy increases exponentially. Majority of electrical power systems are aiming to reduce their dependency toward fossil fuels due to their growing concerns for environment, fuels prices and sustainable development. The research in renewable energy has become an increasingly important topic in the modern era with the problem of energy crisis becoming more and more aggravating, resulting in increased exploitation and research for new power energy resources such as wind, tide, geothermal and solar energy around the world [1].

Solar energy generators are extensively used to harness power from solar irradiation. Solar power is converted into electric power by photovoltaic (PV) panels. The output power of the PV panels depends on the surrounding weather conditions like sun irradiance levels and temperature. The electric characteristics of solar PV panel are affected by these conditions [2]. It can be observed that under certain irradiance levels, unique points exist where the output power from each solar panel is Maximum. These points on the P-V curves are known as the maximum power points (MPPs). The idea of MPPT is developed in the solar system to utilize PV panels at the optimal efficiency by tuning the duty cycles of the power converters inserted between PV source and the load. Different MPPT techniques have been proposed in the literature for PV power generation such as Perturb & Observe algorithm [3], incremental conductance, short circuit current, the hill climbing search and some other special methods such as fuzzy logic technique, neural network etc. The P&O method is mostly used due to its ease of implementation.

The global concern about climate change and the growing energy demand of industrialized countries have necessarily led to exploring other new sources like renewable energy. The main advantage of this type of renewable energy is that it results in reduction of pollution caused by production of greenhouse gases which alternately affects human health and ozone layer [4]–[6]. Among different type of renewable energies the photovoltaic energy has attained great attention. Photovoltaic power supplied to the utility grid is gaining more and more attention nowadays [7]. Numerous inverter circuits and control schemes can be used for PV power conditioning system. For residential PV power generation systems, single-phase utility interactive inverters are of particular interest [8]–[10]. However, depending on the characteristics of the PV panels, the total output voltage from the PV panels varies greatly due to different temperature, irradiation conditions, and shading and clouding effects. Thus, the input voltage of a residential PV inverter can vary widely. Therefore, a dc–dc converter has been used. Such a dc–dc converter in conjunction with a dc–ac inverter arrangement has been widely used in the state-of-the-art PV power conditioning system. In

grid connected photovoltaic system, the photovoltaic system is connected to the grid through three phase or single phase inverter to deliver power directly to the utility grid.

However the effective use of solar energy in a grid connected system is a very big problem [11] and availability of solar energy depends on weather conditions and time of usage. Grid connected photovoltaic is widely used for projects producing bulk amount of power. Due to intermittent nature of Photovoltaic source, supplies from PV cells are variable in nature and must be conditioned as per the demand of the utility grid. This can be done in two ways i) Single stage operation and ii) Two stage operation[4]-[5]. Single stage operation consists of inverter that inverts the DC output voltage provided by the PV cells to AC as per the demand of utility grid [9]-[10]. Whereas in two stage operation the DC voltage provided by the PV cells are first step up by the boost converter and then inverted into AC as per demand of utility grid [16].

Single-phase grid-connected inverters with DC-links are widely used in residential PV systems. In such a PV inverter, the DC-link capacitor plays an important role of decoupling DC power and AC power and buffering energy to ride through power disturbances. Reducing the DC-link capacitance helps to lower the cost, improve reliability and increase power density of inverters, which, however, increases the voltage ripple and reduces the ride-through capability. Therefore, a high performance DC-link voltage controller with fast response is desirable to keep the voltage in a safe operating range when the DC-link capacity is small. Conventionally, a PI controller is adopted to regulate the DC-link voltage as the outer loop, and it provides the AC current reference to the current regulator that works as the inner loop.

Lyapunov stability analysis method is widely used for stability analysis of the equilibrium point, Lyapunov direct method is used to analyze the stability properties of the equilibrium point by studying the energy of the system [17].

Grid-connected inverter plays an important role in injecting high-quality power into the grid [18]. In the grid-connected inverter, an output filter is needed to attenuate the switching harmonics. Compared with an LCL filter, an L filter is considered to be a preferred option due to the resonance hazard of the LCL filter, damping solutions are required to stabilize the system [19].

## II. MODELLING OF GRID CONNECTED PV SYSTEM

This section presents the equations used for modeling each component in the grid connected Photovoltaic system. The primary objective of grid connected PV system is to transform solar energy into electrical energy and to deliver this generated energy into utility grid efficiently. The grid connected system comprises of PV panels arranged in series or parallel fashion or combination of both for production of maximum power, DC/DC converter for power conditioning, DC/AC inverter and passive filter for reduction of harmonics. In this research paper the array consists of nine panels arranged in a series fashion, each of which are 213.15 Watts delivering total of 1916 Watts into the utility grid. To raise the output voltage, each panel comprises of 60 cells linked in a series fashion. The basic parameter

temperature and irradiance of the solar panel is fixed and held constant at 25 0C and 1000 W/m<sup>2</sup>.

### A. Single stage grid connected PV system

In single stage operation the photovoltaic array is directly connected with the utility power network through PV inverter as shown in Fig. 1. In this case the maximum power point tracking and delivery of real power to the grid is achieved by the inverter stage itself.

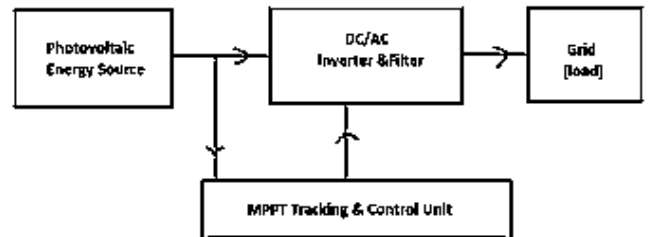

Fig. 1 Single stage grid connected PV system

### B. Two stages grid connected PV System

In two stages operation the voltage from the PV generator is first step up through DC/DC boost converter and then the boost voltage is sent to the PV inverter for further delivery into the grid as shown in Fig. 2. In case of two stages operation the maximum power point tracking is achieved by the DC/DC converter stage and DC/AC inverter stage delivers real power into the utility grid.

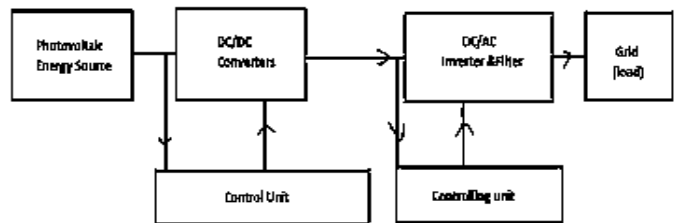

Fig. 2 Two stages grid connected PV system

### C. Modeling of boost converter

The boost converter is a power processing and conditioning device used to increase the voltage level to the amount required at the input of inverter. The voltage generated by the PV panel is low and is step up by DC/DC boost converter, so that inverter does not involve any transformer to supply power into the utility grid. The operation and controlling of DC/DC boost converter is achieved with the help of pulse width modulation (PWM) technique in order to obtain highest amount of power from PV generator. Switching device is used for ON/OFF purpose, inductor for maintaining constant current, capacitor for charging purpose and diode to avoid flow of current in the reverse direction. Some components employed in the boost converter with the aim to increase the voltage level as shown in Fig. 3.

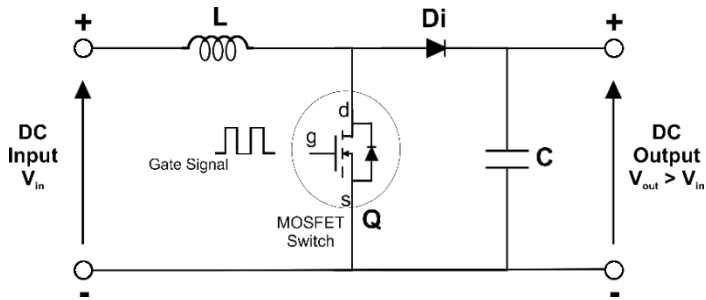

Fig. 3 Control of DC/DC boost converter

#### D. Modeling of L filter

The PV inverter is connected into the utility grid through passive filter in order to reduce harmonic distortion. In order to enhance the quality of output the passive filter used in this research work is L filter. The proposed filter is the first order filter due to which L filter is simple to design and implement.

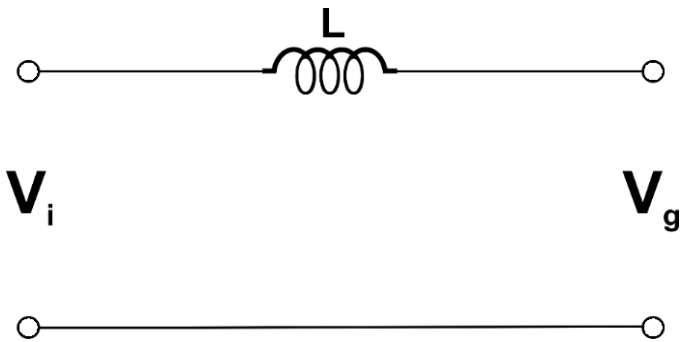

Fig. 4 Schematic of L filter

The current harmonics is due to switches in inverter is operating at high switching frequencies which ultimately results in high switching losses. In case of L filter switches generate an input (voltage) for the inductor and the output of inductor will be current. Then the output of the L filter which is actually the current to be feed into the grid, serve as the input to the utility grid and the output of the utility grid will be in the form constant AC voltage suitable for utilization. The schematic of the proposed filter is shown in Fig. 4.

### III. MATHEMATICAL MODELLING AND CONTROLLER DESIGNING

To achieve the purpose and objective this research work nonlinear control mechanism is proposed based on accurate mathematical modeling of Photovoltaic generator interfaced with weak grid system in terms of state space equation by using Backstepping technique and Lyapunov stability tool. Photovoltaic generating unit connected to weak grid system is designed and modeled in MATLAB/Simulink environment. For model designing and mathematical modeling it is necessary to make some assumptions. First is that consider all switches are ideal and their resistance can be easily ignored. Second assumption is that consider resistance of all inductors and capacitors are very low and can also be neglected. The entire system architecture consists of PV panels arranged in a series fashion, DC/DC boost converter for increasing voltage magnitude, H-Bridge inverter for production of AC output

voltage and L filter for reduction of harmonics is connected to weak utility grid as shown in Fig. 5.

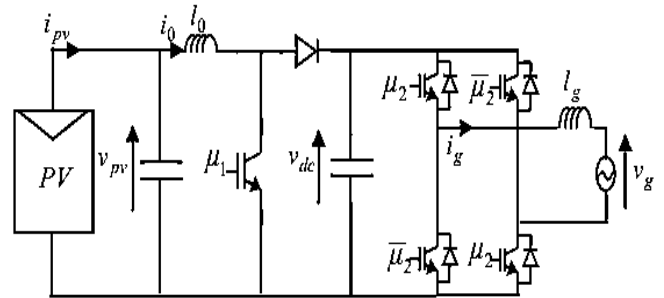

Fig. 5 Grid connected PV system

Basic circuit laws are applied to figure 5 in order to obtain differential equations. By applying KCL at PV side,

$$I_{PV} = I_0 + I_{CPV}$$

$$I_{CPV} = I_{PV} - I_0$$

As  $I_C = C \, dV/dt$

$$C_{PV} \, dV_{PV}/dt = I_{PV} - I_0 \dots (i)$$

By applying KCL at Grid side,

$$I_0 = I_0 u_1 + I_C + I_g u_2$$

$$I_C = I_0 - I_0 u_1 - I_g u_2$$

$$C_{dc} \, dV_{dc}/dt = I_0 (1 - u_1) - I_g u_2 \dots (ii)$$

Applying KVL on PV side,

$$V_{L0} + V_{dc} = V_{pv} + V_{dc} u_1$$

$$L_0 dI_0/dt = V_{pv} - V_{dc} (1 - u_1) \dots (iii)$$

Applying KVL on Grid side,

$$V_g + V_{Lg} = V_{dc} u_2$$

$$L_g dI_g/dt = V_{dc} u_2 - V_g \dots (iv)$$

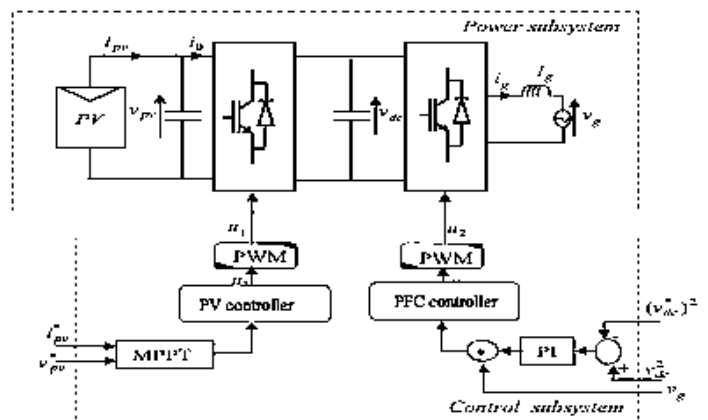

Fig. 6 Control circuit of grid connected PV system

The control circuit schematic of grid connected PV system is shown in Fig. 6 help us in designing and implementation of various controllers. The block diagram shown is to be simulated and implemented in Simulink/Matlab.

The differential equations obtained from instantaneous model cannot be used directly for controller design as it involves the binary inputs and in this research work control input needs to be of switched nature. For this purpose averaging model is used in the form of state space equations.

The above differential equations (i-iv) of grid connected Photovoltaic system can be expressed in the form of state space equation as,

$$C_{pv} \dot{g}_1 = I_{pv} - g_2 \quad (1)$$

$$L_0 \dot{g}_2 = g_1 - (1-u_1) g_3 \quad (2)$$

$$C_{dc} \dot{g}_3 = (1-u_1) g_2 - u_2 g_4 \quad (3)$$

$$L_g \dot{g}_4 = u_2 g_3 - V_g \quad (4)$$

The  $g_1, g_2, g_3$  and  $g_4$  used in the above equations are the state variables. Whereas  $g_1$  represent voltage produced by PV array ( $V_{pv}$ ). While  $g_2, g_3$  and  $g_4$  represents input current to the boost converter ( $i_o$ ), input voltage into the inverter ( $V_{dc}$ ) and output current of the inverter ( $i_{grid}$ ) respectively. Whereas  $u_1$  and  $u_2$  represents are the switching functions for converters.

#### A. PV Generator Voltage Controller Designing

The objective of designing this controller is to enable and enforce the voltage produced by the photovoltaic generator to follow the reference voltage ( $g_1, ref$ ) generated by the P&O MPPT technique. To achieve this objective an error signal is generated between the reference value and the actual value. Backstepping controller will enable the photovoltaic generator voltage to track the reference voltage provided by the P&O MPPT algorithm and vanish the error variable. The stability of the system is validated by Lyapunov Stability method.

Let us introduce an error,  $e_1$  between PV output voltage and the reference voltage.

$$e_1 = C_{pv} (g_1 - g_{1, ref})$$

The derivative of  $e_1$  w.r.t time is,

$$\dot{e}_1 = C_{pv} \dot{g}_1 - C_{pv} \dot{g}_{1, ref}$$

Putting the value of Eq. (1) in above Equation,

$$\dot{e}_1 = \dot{i}_{pv} - g_2 - C_{pv} \dot{g}_{1, ref} \quad (5)$$

The stability of Eq. (5) is validated by using Lyapunov stability technique. Consider Lyapunov function candidate,

$$X_1 = \frac{1}{2} e_1^2$$

Taking derivatives of  $X_1$  w.r.t is,

$$\dot{X}_1 = e_1 \dot{e}_1$$

Putting  $\dot{e}_1 = -c_1 e_1$

$$\dot{X}_1 = -c_1 e_1^2 \quad (6)$$

As the Eq. (6) is a negative definite, where  $c_1$  is a positive design parameter and by putting any positive value in the above equation will get  $\dot{X}_1$  less than or equal to zero, which shows the system is stable.

$$\dot{X}_1 \leq 0$$

As  $g_2$  is viewed as input and proceeds to the design of actual control input,  $u_1$ , so we take it as a reference. From Eq. (5),

$$\begin{aligned} \dot{e}_1 &= \dot{i}_{pv} - g_2, ref - C_{pv} \dot{g}_{1, ref} \\ -c_1 e_1 &= \dot{i}_{pv} - g_2, ref - C_{pv} \dot{g}_{1, ref} \end{aligned}$$

$$\begin{aligned} g_2, ref &= c_1 e_1 + \dot{i}_{pv} - C_{pv} \dot{g}_{1, ref} \\ C_{pv} \dot{g}_{1, ref} &= \dot{i}_{pv} + c_1 e_1 - g_2, ref \end{aligned} \quad (7)$$

Putting Eq. (7) in Eq. (5),

$$\begin{aligned} \dot{e}_1 &= \dot{i}_{pv} - g_2 - (\dot{i}_{pv} + c_1 e_1 - g_2, ref) \\ \dot{e}_1 &= -c_1 e_1 - (g_2 - g_2, ref) \end{aligned} \quad (8)$$

As  $g_2, ref$  is just a variable and not an actual controller. It is a reference for boost converter current,  $g_2$ .

Let us introduce new error,  $e_2$  between the reference value and the desired value.

$$e_2 = L_0 (g_2 - g_2, ref) \quad (9)$$

$$e_2 / L_0 = (g_2 - g_2, ref) \quad (10)$$

Putting Eq. (10) in Eq. (8) we get,

$$\dot{e}_1 = -c_1 e_1 - e_2 / L_0 \quad (11)$$

Take derivative of Eq. (9) w.r.t,

$$\dot{e}_2 = L_0 \dot{g}_2 - L_0 \dot{g}_{2, ref} \quad (12)$$

Putting values of  $L_0 \dot{g}_2$  from Eq. (2) in Eq. (12)

$$\dot{e}_2 = g_1 - (1-u_1) g_3 - L_0 \dot{g}_{2, ref} \quad (13)$$

To check the stability of the system while defining second error variable using Lyapunov stability technique, we use both variables. Consider Lyapunov function candidate,

$$X_2 = X_1 + \frac{1}{2} e_2^2$$

Take derivative of  $X_2$  w.r.t is,

$$\dot{X}_2 = \dot{X}_1 + e_2 \dot{e}_2 \quad (14)$$

$$\dot{X}_2 = -c_1 e_1^2 + e_2 (-c_2 e_2)$$

$$\dot{X}_2 = -c_1 e_1^2 - c_2 e_2^2 \quad (15)$$

The Eq. (15) is a negative definite, where  $c_1$  and  $c_2$  are positive design parameters. By putting any positive value of  $c_1$  or  $c_2$  will results in  $\dot{X}_2$  less than or equal to zero, showing the stability of the system.

$$\dot{X}_2 \leq 0$$

From the above conclusions controller for PV generator is designed in the following manner by considering Eq. (13).

$$\dot{e}_2 = g_1 - g_3 (1-u_1) - L_0 \dot{g}_{2,ref}$$

Suppose  $-c_2 e_2 = \dot{e}_2 - e_1/L_0$

$$\dot{e}_2 = -c_2 e_2 + e_1/L_0$$

Putting values of  $\dot{e}_2$  in Eq. (13)

$$-c_2 e_2 + e_1/L_0 = g_1 - g_3 (1-u_1) - L_0 \dot{g}_{2,ref}$$

$$g_3 (1-u_1) = g_1 - L_0 \dot{g}_{2,ref} + c_2 e_2 - e_1/L_0$$

$$1-u_1 = 1/g_3 (g_1 - L_0 \dot{g}_{2,ref} + c_2 e_2 - e_1/L_0)$$

$$u_1 = 1 - 1/g_3 (g_1 - L_0 \dot{g}_{2,ref} + c_2 e_2 - e_1/L_0) \quad (16)$$

Eq. (16) is a designed control law for boost converter operation.

### B. DC Link Voltage Controller Designing

The objective of designing this controller is to maintain constant voltage at the input of the inverter. The voltage available at the input of the inverter serves as the source for the grid and any changes in this input voltage vary the current to the inverter and hence changes power flow to the utility grid system. To achieve the purpose proportional integral (PI) controller is used to generate specific value of  $\beta$  and tune that value of  $\beta$  to such a degree as to forces the voltage at the input of the inverter,  $g_3$  to track a given reference value,  $g_{3,ref}$ . Actually PI controller will regulate the square of output voltage to track a demanded reference value.

PI controller is tuned in such a way,

$$\beta = (k_p + k_i/s) (g_3 - g_{3,ref}) \quad (17)$$

In case of single stage operation the maximum voltage produced by the PV array will be the reference voltage, whereas in case of two stage operation reference voltage is taken as 400 V.

### C. Power Factor Controller Designing

The main objective of this controller is to deliver power from PV array into the utility grid at unity power factor. The controller will generate reference value. The reference value is the multiplication of grid voltage and the output of the PI controller i.e.  $g_{4,ref} = \beta V_g$ . Backstepping controller enable the current,  $g_4$  at the output of inverter to track the reference value. When current at output of inverter succeeds in achieving the reference value, then at this point current at the output of inverter and grid voltage will be synchronized and in phase with each other.

From Eq. (4) and using Backstepping approach,

$$L_g \dot{g}_4 = u_2 g_3 - V_g$$

Let us introduce current,  $e_4$  between grid current and reference value,

$$e_4 = L_g (g_4 - g_{4,ref})$$

Take derivatives of  $e_4$  w.r.t is,

$$\dot{e}_4 = L_g \dot{g}_4 - L_g \dot{g}_{4,ref} \quad (18)$$

Putting the values of Eq. (4) in Eq. (18)

$$\dot{e}_4 = g_3 u_2 - V_g - L_g \dot{g}_{4,ref} \quad (19)$$

Consider Lyapunov function candidate, in order to check the stability of the system.

$$X_4 = \frac{1}{2} e_4^2$$

Take derivative w.r.t,

$$\dot{X}_4 = e_4 \dot{e}_4$$

$$\dot{X}_4 = -c_4 e_4^2 \quad (20)$$

As Eq. (20) is a negative definite and  $c_4$  is a positive design parameter. Putting any positive value of  $c_4$  in the above equation results in  $\dot{X}_4$  less than or equal to zero, showing the system is stable.

$$\dot{X}_4 \leq 0$$

Putting  $\dot{e}_4 = -c_4 e_4$ , in Eq. (19)

$$-c_4 e_4 = g_3 u_2 - V_g - L_g \dot{g}_{4,ref}$$

$$u_2 = 1/g_3 (-c_4 e_4 + V_g + L_g \dot{g}_{4,ref}) \quad (21)$$

Eq. (21) is the control law for power factor correction.

The stability of the controller is validated using Lyapunov stability technique. Consider Lyapunov function candidate,

$$X_4 = \frac{1}{2} e_4^2$$

Take derivative w.r.t,

$$\dot{X}_4 = e_4 \dot{e}_4 \tag{22}$$

Putting Eq. (19) in Eq. (22)

$$\dot{X}_4 = e_4 (g_3 u_2 - V_g - L_g \dot{g}_{4, ref}) \tag{23}$$

Putting Eq. (21) in Eq. (23)

$$\dot{X}_4 = e_4 [g_3 \{1/g_3 (-c_4 e_4 + V_g + L_g \dot{g}_{4, ref})\} - V_g - L_g \dot{g}_{4, ref}]$$

$$\dot{X}_4 = e_4 (-c_4 e_4) \tag{24}$$

The Eq. (24) is a negative definite and putting any positive value of  $c_4$  will result in  $\dot{X}_4$  less than or equal to zero, showing the system is stable.

$$\dot{X}_4 \leq 0$$

#### IV. RESULTS AND SIMULATION

Both single stage and two stages photovoltaic inverter connected to weak grid system are simulated in MATLAB/Simulink environment and then compare the results by evaluating the overall performance. The operation and control of grid connected photovoltaic system shown in fig. 3 is designed and simulated in MATLAB/Simulink environment. The simulation and comparison results are shown in Fig. 7-17.

The Fig. 7 and Fig. 8 shows comparison of PV voltage provided by the PV array and tracking of reference voltage provided by the P&O MPPT algorithm. On comparison PV voltage in case of two stage operation shows fast and better response in tracking the reference voltage.

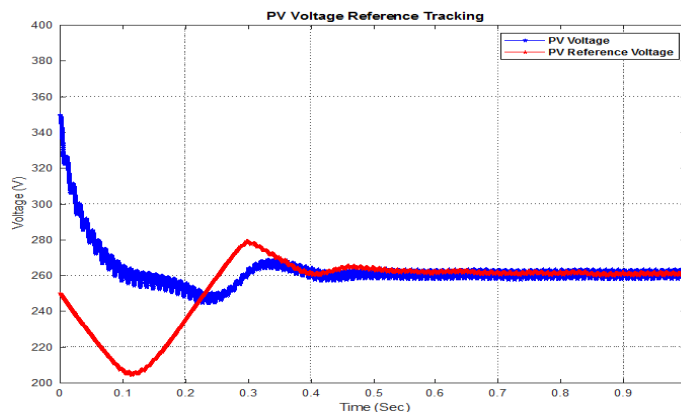

Fig. 7 PV voltage reference tracking (single stage)

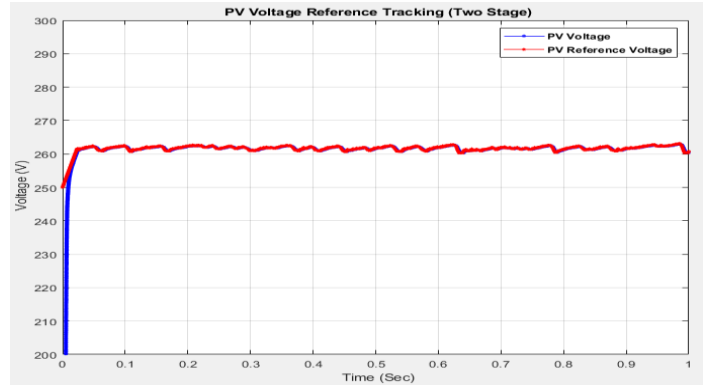

Fig. 8 PV voltage reference tracking (double stage)

The Fig. 9 and Fig. 10 shows regulation of voltage at input of the inverter to the desired voltage value. The two stage operation has fast and better response in tracking the desired voltage value.

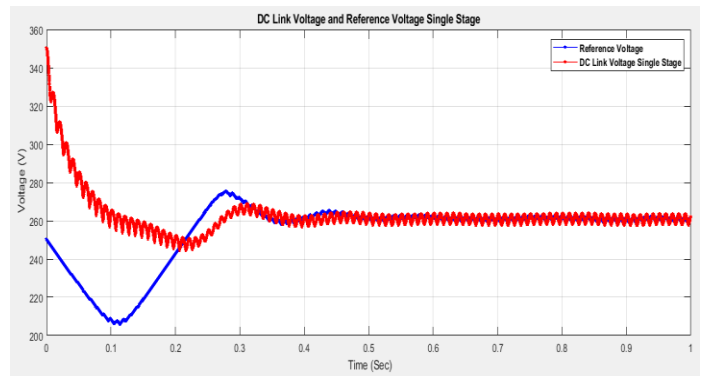

Fig. 9 DC link voltage regulation (single stage)

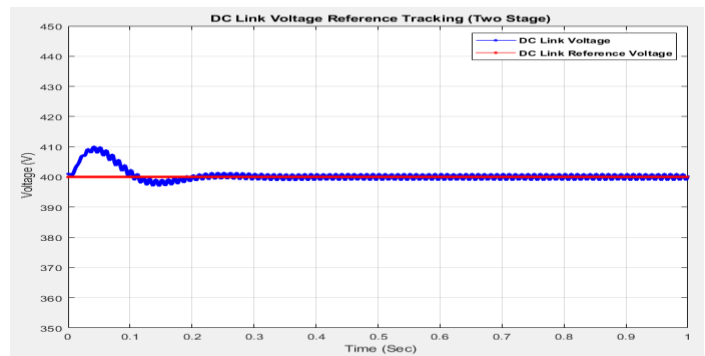

Fig. 10 DC link voltage regulation (double stage)

The Fig. 11 shows maximum amount of power generation by PV array that is approximately 1916 Watts in case of two stage operation. The Fig. 12 shows the amount of real power delivery to the weak grid system. In case of two stages operation inverter deliver maximum real power to the grid with minimum of distortions.

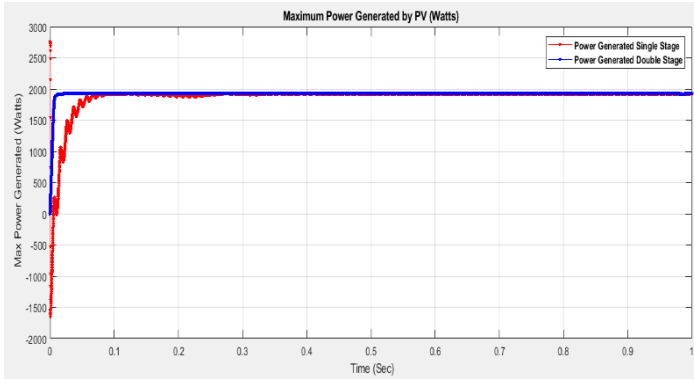

Fig. 11 Maximum power generation

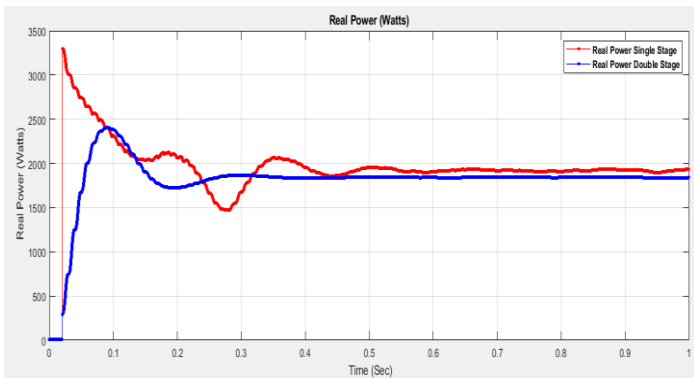

Fig. 12 Real power

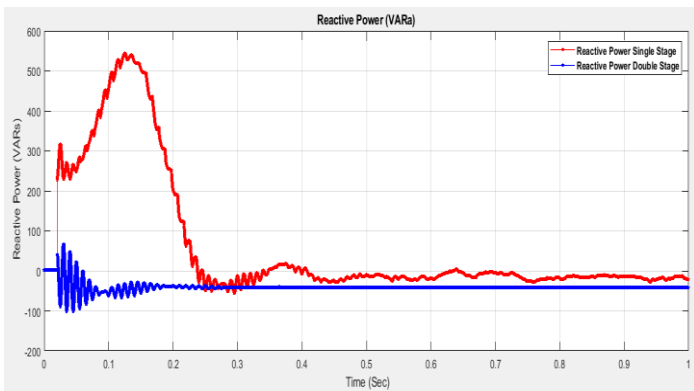

Fig. 13 Reactive power

The Fig. 14 and Fig. 15 shows comparison of synchronization of inverter output current and grid voltage in case of single stage and two stage operation. The inverter output current and grid voltage are synchronized and in phase with each other in both cases. The current is more sinusoidal in case of two stage operation and has better and distortion less response which leads to delivery of real power to the grid at unity power factor.

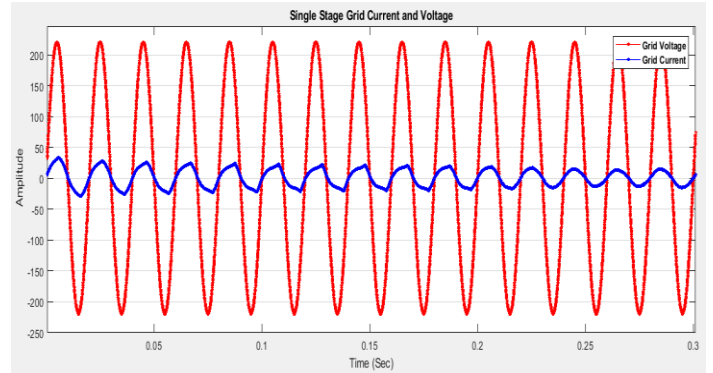

Fig. 14 Output current and grid voltage (single stage)

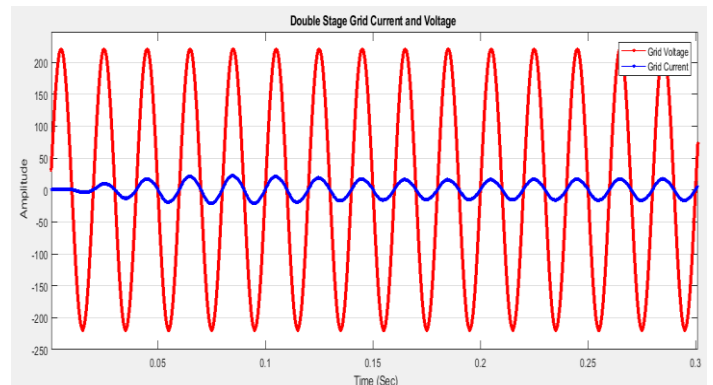

Fig. 15 Output current and grid voltage (two stage)

The Fig. 16 shows comparison of power factor in case of single stage and two stage operation. In both cases the inverter output current and grid voltage are in phase with each other. The two stage operation has smooth and better power factor response that is power factor is approximately near to unity.

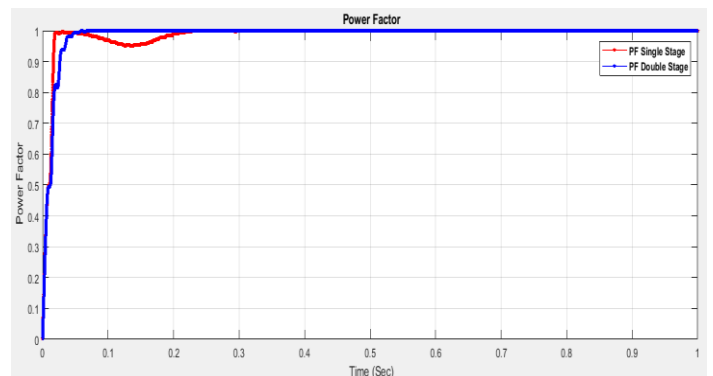

Fig. 16 Power factor

The Fig. 17 shows the overall efficiency comparison of single stage and two stages operation. The two stage operation has proved to have better and higher efficiency.

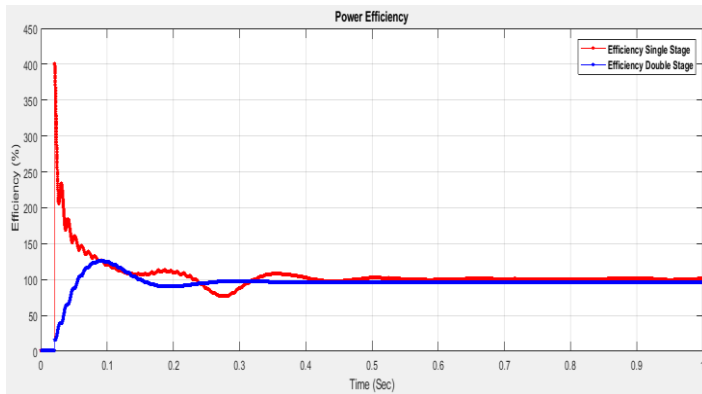

Fig. 17 Power efficiency

### CONCLUSION

From the simulation results it can be easily concluded that two stages grid connected PV inverter has better and stable response as compared to the single stage grid connected PV inverter. Two stages operation has proved to have high efficiency, almost unity power factor and higher accuracy of tracking reference voltage. However two stages grid connected PV system has very complex structure and will have requires high investment in the beginning as compared to single stage grid connected PV system.

### REFERENCES

[1] D. Poponi, "Analysis of diffusion paths for photovoltaic technology based on experience curves," *Sol. Energy*, vol. 74, no. 4, pp. 331–340, Apr. 2003, doi: 10.1016/S0038-092X(03)00151-8.

[2] Fangrui Liu, Yong Kang, Yu Zhang, and Shanxu Duan, "Comparison of P&#x0026;O and hill climbing MPPT methods for grid-connected PV converter," in *2008 3rd IEEE Conference on Industrial Electronics and Applications*, Singapore, Jun. 2008, pp. 804–807, doi: 10.1109/ICIEA.2008.4582626.

[3] N. Femia, G. Petrone, G. Spagnuolo, and M. Vitelli, "Optimization of Perturb and Observe Maximum Power Point Tracking Method," *IEEE Trans. Power Electron.*, vol. 20, no. 4, pp. 963–973, Jul. 2005, doi: 10.1109/TPEL.2005.850975.

[4] B. M. T. Ho and H. S.-H. Chung, "An Integrated Inverter With Maximum Power Tracking for Grid-Connected PV Systems," *IEEE Trans. Power Electron.*, vol. 20, no. 4, pp. 953–962, Jul. 2005, doi: 10.1109/TPEL.2005.850906.

[5] Bo Yang, Wuhua Li, Yi Zhao, and Xiangning He, "Design and Analysis of a Grid-Connected Photovoltaic Power System," *IEEE Trans. Power Electron.*, vol. 25, no. 4, pp. 992–1000, Apr. 2010, doi: 10.1109/TPEL.2009.2036432.

[6] Yeong-Chau Kuo, Tsorng-Juu Liang, and Jiann-Fuh Chen, "Novel maximum-power-point-tracking controller for photovoltaic energy conversion system," *IEEE Trans. Ind. Electron.*, vol. 48, no. 3, pp. 594–601, Jun. 2001, doi: 10.1109/41.925586.

[7] A. Koran, K. Sano, and R.-Y. Kim, "Design of a Photovoltaic Simulator with a Novel Reference Signal Generator and Two-Stage LC Output Filter," p. 8.

[8] D. Casadei, G. Grandi, and C. Rossi, "Single-Phase Single-Stage Photovoltaic Generation System Based on a Ripple Correlation Control Maximum Power Point Tracking," *IEEE Trans. Energy Convers.*, vol. 21, no. 2, pp. 562–568, Jun. 2006, doi: 10.1109/TEC.2005.853784.

[9] Y. Huang, M. Shen, F. Z. Peng, and J. Wang, "\$Z\$-Source Inverter for Residential Photovoltaic Systems," *IEEE Trans. Power Electron.*, vol. 21, no. 6, pp. 1776–1782, Nov. 2006, doi: 10.1109/TPEL.2006.882913.

[10] S. B. Kjaer, J. K. Pedersen, and F. Blaabjerg, "A Review of Single-Phase Grid-Connected Inverters for Photovoltaic Modules," *IEEE*

*Trans. Ind. Appl.*, vol. 41, no. 5, pp. 1292–1306, Sep. 2005, doi: 10.1109/TIA.2005.853371.

[11] V. Ravindran, S. K. Ronnberg, T. Busatto, and M. H. J. Bollen, "Inspection of interharmonic emissions from a grid-tied PV inverter in North Sweden," in *2018 18th International Conference on Harmonics and Quality of Power (ICHQP)*, Ljubljana, May 2018, pp. 1–6, doi: 10.1109/ICHQP.2018.8378887.

[12] B. N. Alajmi, K. H. Ahmed, G. P. Adam, and B. W. Williams, "Single-Phase Single-Stage Transformer less Grid-Connected PV System," *IEEE Trans. Power Electron.*, vol. 28, no. 6, pp. 2664–2676, Jun. 2013, doi: 10.1109/TPEL.2012.2228280.

[13] L. Chen, A. Amirahmadi, Q. Zhang, N. Kutkut, and I. Batarseh, "Design and Implementation of Three-Phase Two-Stage Grid-Connected Module Integrated Converter," *IEEE Trans. Power Electron.*, vol. 29, no. 8, pp. 3881–3892, Aug. 2014, doi: 10.1109/TPEL.2013.2294933.

[14] H. Hu, S. Harb, N. H. Kutkut, Z. J. Shen, and I. Batarseh, "A Single-Stage Microinverter Without Using Electrolytic Capacitors," *IEEE Trans. Power Electron.*, vol. 28, no. 6, pp. 2677–2687, Jun. 2013, doi: 10.1109/TPEL.2012.2224886.

[15] N. Suresh, M. Pahlevaninezhad, and P. K. Jain, "Analysis and Implementation of a Single-Stage Flyback PV Microinverter With Soft Switching," *IEEE Trans. Ind. Electron.*, vol. 61, no. 4, pp. 1819–1833, Apr. 2014, doi: 10.1109/TIE.2013.2263778.

[16] Y.-H. Kim, Y.-H. Ji, J.-G. Kim, Y.-C. Jung, and C.-Y. Won, "A New Control Strategy for Improving Weighted Efficiency in Photovoltaic AC Module-Type Interleaved Flyback Inverters," *IEEE Trans. Power Electron.*, vol. 28, no. 6, pp. 2688–2699, Jun. 2013, doi: 10.1109/TPEL.2012.2226753.

[17] C. Meza, D. Biel, D. Jeltsema, and J. M. A. Scherpen, "Lyapunov-Based Control Scheme for Single-Phase Grid-Connected PV Central Inverters," *IEEE Trans. Control Syst. Technol.*, vol. 20, no. 2, pp. 520–529, Mar. 2012, doi: 10.1109/TCST.2011.2114348.

[18] F. Blaabjerg, R. Teodorescu, M. Liserre, and A. V. Timbus, "Overview of Control and Grid Synchronization for Distributed Power Generation Systems," *IEEE Trans. Ind. Electron.*, vol. 53, no. 5, pp. 1398–1409, Oct. 2006, doi: 10.1109/TIE.2006.881997.

[19] J. He and Y. W. Li, "Generalized Closed-Loop Control Schemes with Embedded Virtual Impedances for Voltage Source Converters with LC or LCL Filters," *IEEE Trans. Power Electron.*, vol. 27, no. 4, pp. 1850–1861, Apr. 2012, doi: 10.1109/TPEL.2011.2168427.

### How to cite this article:

Naveed Malik, Sami Ullah, Amir Khan and Farhan Ullah, Designing and Analysis of Single Stage and Two Stage PV Inverter Connected to Weak Grid System, *International Journal of Engineering Works*, Vol. 7, Issue 10, PP. 361-369, October 2020, <https://doi.org/10.34259/ijew.20.710361368>.

