



Performance of UPFC to enhance Power Stability in Multi-Machine Power System under Fault Condition

Shah Munir Khan, Muhammad Naeem Arbab

Abstract— Modern power systems are interconnected and exposed to external as well as internal disturbances. The stable operation of power system (Power System Stability) is the subject of great interest for power engineers for the last few decades. Stability in power system is achieved by many means, but nowadays FACTS controllers, which are a family of flexible alternating current transmission system devices, are widely used to enhance stability. Among these is the unified power flow controller (UPFC), the most versatile and prominent that controls the flow of active power and reactive power and also stabilize the voltage at selected bus. This paper presents an approach towards stability using UPFC in multi-machine power system. The proposed work is implemented in MATLAB/SIMULINK. The power system is simulated with and without UPFC to check the performance of the controller under fault condition. The simulation results show that in case when UPFC is used it takes much less time to enhance power stability after fault occurrence compared to the case without using UPFC.

Keywords— Power System Stability, FACTS, UPFC, Multi-Machine

I. INTRODUCTION

Electric Power system consists of generation, transmission, distribution and many ancillary devices such as controllers, regulators and protecting devices. Load is also an important part of the power system because the sole purpose of the main components is to feed the load. However there is often mismatch between supply and demand. This and the variable nature of load affect the performance and stability of power system. In power system there always arise the problem of stability. Stability is the set of measures taken to maintain the system components in synchronism. When fault occur in any part it will result in an abnormal flow of power, affects the voltage and also cause the system to oscillate. To damp out the oscillations and enhance stability, various types of FACTS devices are used [1]-[3]. Since the birth of AC system and problem of stability, a group of mechanical switches comprises of capacitor and reactors were used [4]. But there use is avoided due to their slow response. To overcome the deficiency the family of FACTS devices is introduced by EPRI (Electric Power Research Institute) in 1980[5]. According to the definition FACTS are power electronics fast

acting static switches that are used to control, design and operate the power system [6].

The organization of the paper is section I is the general introduction. Section II is about the structure and features of UPFC. The proposed multi-machine power system is explained in section III. Whereas the simulation and results are illustrated in section IV. Finally section V concludes.

II. THE UPFC

UPFC is the most important member of FACTS devices family. It can enhance dynamic stability, transient stability and steady state stability [2]. Its unique feature is that it can control power flow, impedance, phase angle and voltage. This control of parameters can be selective or simultaneous [7]. Figure 1. shows the basic structure of UPFC. It consist of two converters, series and shunt transformer and a dc link capacitor.

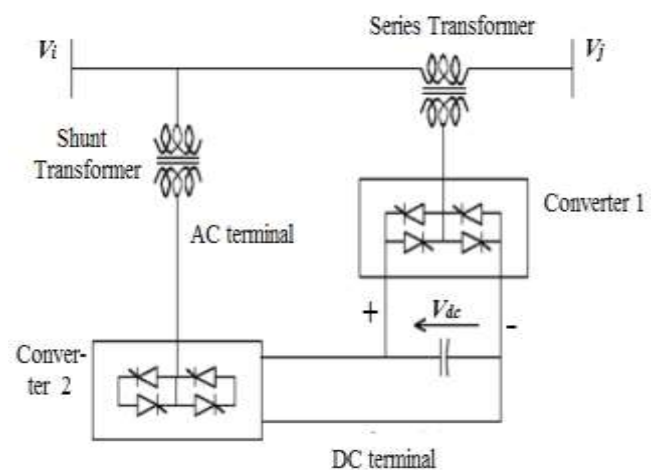

Figure 1. Configuration of UPFC

It combines the features of static synchronous series compensator (SSSC) and static synchronous compensator (STATCOM)[8]. The maximum defined voltage to transmission line is injected by series converter by adjusting phase angle from 0 to 2π . The injection is performed through boostable series transformer. This behaves as voltage source and can absorb or generate reactive power thus transferring

active/real power. The DC link maintains a constant voltage and provides path for the flow of active power. The primary purpose of shunt converter is providing real power to the series converter on demand. The shunt converter is capable of absorbing or generating reactive power and performing the function of STATCOM. The reactive power to the system is exchanged through both series and shunt converter. However, the real power is supplied through the DC link which is taken from the shunt converter.

III. POWER SYSTEM UNDER STUDY

The power system shown in Figure 2. is a multi-machine infinite bus system consisting of two generators G1 and G2 having a combined capacity of 1500 MW. Both generators are equipped with an excitation system, hydro turbine, and governor and PSS.

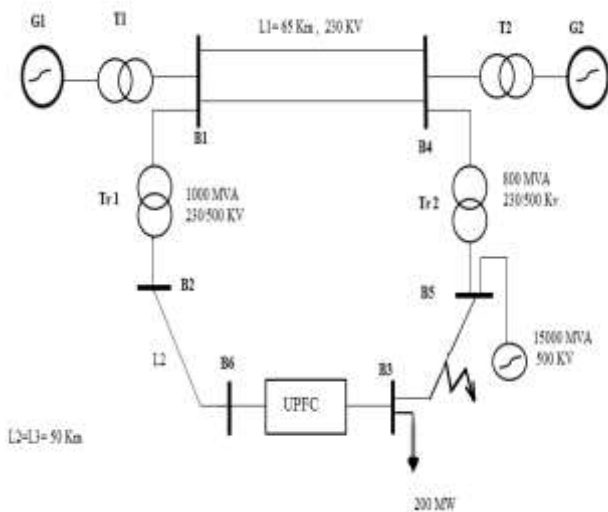

Figure 2. Single Line Diagram of Power System under study

The system is interconnected through six buses (B1-B6) and four step-up transformers T1, T2, Tr1 and Tr2. Tr1 is 1000 MVA, 230KV/500KV and connected between Bus1 and Bus 2. Tr2 is 800 MVA, 230KV/500KV and connected between Bus 4 and Bus 5. A load of 200 MW is connected to Bus 3. An equivalent of 15000 MVA is connected to Bus 5 to balance the circuit. The system parameters and data are given in Appendix A.

IV. SIMULATION RESULTS AND DISCUSSION

The power system shown by the single diagram in Figure 2. is considered in the study. UPFC is connected between Bus 3 and Bus 6. A single phase fault of 100ms duration is created at Bus3.

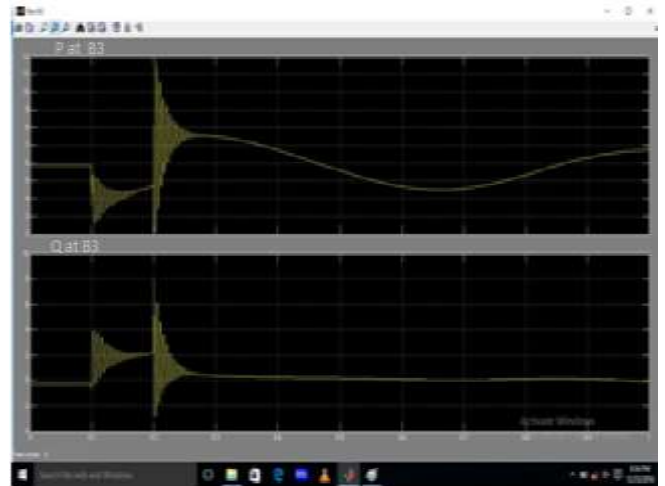

Figure 3. Single phase fault at Bus 3 without UPFC

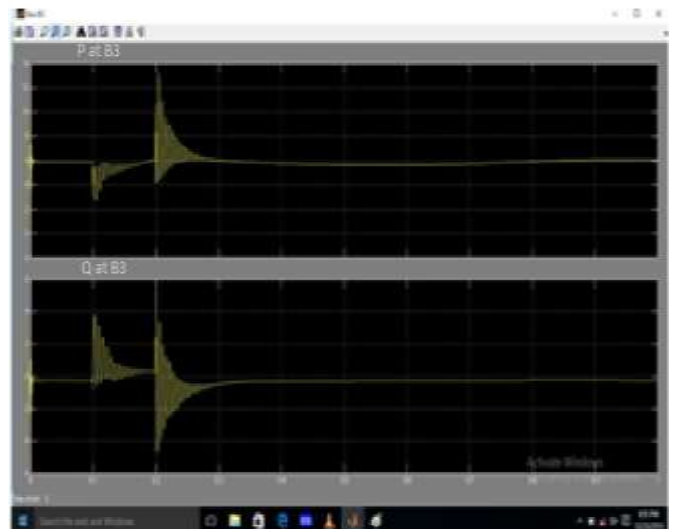

Figure 4. Single Phase fault at Bus 3 using UPFC

Pref and Qref values are set in the magenta block of the controller at Bus 3 in order to see the effect of the fault. Simulations are carried out in MATLAB/Simulink and the results are presented in the form of PQ waveforms. Figure 3 and Figure 4 illustrate that after the removal of the fault, the real power is stabilized in much less time in the presence of the controller, compared to the case when the controller is not used. Whereas the reactive power is immediately stabilized after removal of the fault in both cases.

V. CONCLUSION

In this paper, a multi-machine power system is presented. The performance of the UPFC is checked under fault conditions. The controller has the advantage to clear the fault quickly as

well as lower the settling time for power stability . From the simulation results it is clear that if the controller is used the fault is cleared in 0.1second and the real power stability is attained soon after the clearance of fault. Whereas it takes 1second to completely stabilizes the system if the controller is not used. In both cases the reactive power remain constant after the removal of fault.

APPENDIX A

Generators Parameters:

G1:500MW, Voltage(line-to-line)=13.8 KV

G2:1000MW, Voltage(line-to-line)=13.8 KV

Transformer Parameters:

Tr1:1000MVA, 13.8/230 KV

Tr2 : 1200MVA, 13.8/230 KV

Connection Type: Delta – Wye(Both)

UPFC Parameters:

500KV, 60Hz

Shunt Converter=100 MVA

Shunt Coverter Imp, R(pu)=0.22/30, L(pu)= 0.22

Series Converter= 100 MVA

Series Converter Imp, , R(pu)=0.16/30, L(pu)= 0.16

DC link voltage=40KV

DC link Total capacitance= 750e-6 F

REFERENCES

- [1] N .G, Hingori and L.Gyungyi, Understanding FACTS, IEEE Press 2001.
- [2] D. Murali and Dr. M Rajaram, “Comparison of FACTS Devices for Power System Stability,” International Journal of Computer Applications, Volume 8-No4 2010.
- [3] Poonam Singhal and Parmard Kumar Madotra, “Transient Stability Enhancement of a Multi-machine Power system using SVC,”

International Journal of Emerging Trends and Technology in Computer Science, Volume 4, Issue 1,2015.

- [4] M.M Eraty and Z Aydogmus “The Simulation Study and Dynamic Analysis of UPFC for industrial and educational purposes,” Volume No 5(121),2012.
- [5] Dr.P.R.Sharma and Dr Rajesh Kr Ahuja, “Performance Analysis of Multi-Machine System using UPFC,” International Journal of Advance Research in Electrical Electronics and Instrumentation Engineering, Volume 3, Issue 6, 2014.
- [6] Vibhor Gupta, “Study and Effects of UPFC and its control system for Power Flow control and voltage injection in a power system,” International Journal of Engineering Science and Technology, Volume 2(7) ,2010
- [7] L.Gyugyi, “ The Unified Power Flow Controller: A new approach to Power transmission control,” IEEE Transiction on Power Delivery, Volume 10, No 2, 1995.
- [8] D.Murali and Dr. M. Rajaram, “Active and Reactive Power Flow control using FACTS Devices,” International Journal of Computer Application, Volume 9- No.8, 2010.



Shah Munir Khan is a student of M.S. in Electrical Engineering Department, University of Engineering and Technology Peshawar, Pakistan. He received B.Sc Electrical Engineering degree from the same university in 2013. His research areas include Power System Control and Energy conversion. munirkhalil711@yahoo.com

Muhammad Naeem Arbab is a professor in Electrical Engineering Department, University of Engineering and Technology Peshawar, Pakistan. He received his Phd and M.Sc degree from UK. He wrote two books i-e, Electrical Power Generation and High Voltage Engineering and published many papers. He is also a member of IEEE. mnarbab@yahoo.com