

## Rural Electrification through an Efficient Regulated System

Muhammad Safdar<sup>1</sup>, Alamgir Ahmad Khattak<sup>2</sup>, Asad Nawaz Khan<sup>3</sup>, Abdul Basit<sup>4</sup>

<sup>1,2,3,4</sup>Department of Electrical Energy Systems Engineering, US Pakistan Centre for Advanced Studies in Energy, University of Engineering and technology Peshawar, Pakistan

salarsafdar@gmail.com<sup>1</sup>, khattak.seecs@gmail.com<sup>2</sup>, p096409@nu.edu.pk<sup>3</sup>, abdul.basit@uetpeshawar.edu.pk<sup>4</sup>

Received: 07 August, Revised: 16 August, Accepted: 19 August

**Abstract**—Due to the environmental concerns the focus is on clean energy generation globally. Hydrokinetic is one such emerging technology that is clean and abundantly available in Pakistan. Also we have energy crises so in areas where these resources are abundant if fed from locally generated electricity, the load on central grid can be reduced. This paper focuses on a battery-less system for hydrokinetics. PMSG is used and then a rectifier to convert its output to DC. This changing DC is then converted to a fixed 12 volts and regulated. Eliminating storage the output of this converter is fed to a UPS which changes it to alternating current of fixed voltage and frequency.

**Keywords**— Buck converter, permanent magnet synchronous generator, hydrokinetic.

### I. BACKGROUND

Pakistan has serious energy crises, this crises has affected every aspect of life from industry to household. Around 40,000 villages which comprises over 3 million households, do not have grid connectivity and depends on cell batteries, coal, kerosene oil, woods or petroleum etc. 7876 of the faraway villages cannot be connected to grid for another 20 years due to the distance from national grid, which leave these villages economically and technically unavailable [1].

On one side the crisis getting worse with each passing day on the other hand the current energy mix is majorly based on thermal sources. The fluctuating prices of oil in the international market affect its cost and supply, as these changes can never be forecasted therefore it's not a reliable source for generating electricity. Coal was considered as a best alternative due to its cheapness and wide availability but nowadays due to the environmental concerns it's also not much preferred [2-4]. Apart from the environmental concerns oil, gas and coal for generation purposes are imported mainly in Pakistan and if the current situation persists it will be a huge burden on the foreign exchange reserves of the country. The energy prices are continuously increasing and this results in the export surplus becoming more uncompetitive, local consumption goods are becoming costlier and some industries could face closure if this trend continues. All these factors pushing the country to a more economic stress. Therefore, there is an urgent need for quicker solutions to the energy crises, a switch over from the conventional to easily exploiting renewable energy resources

which are sustainable and able to meet not only the current but also the projected energy demands of the country [5].

The need for clean and environment friendly techniques is obvious mainly due the environmental impacts of fossil fuels; the fear of depletion of these resources also gearing up this search for newer techniques of extracting clean energy. These resources other than the conventional are named as alternative. Alternative resources “are derived from natural replenish able resources that do not use up necessary resources or harm environment”. Currently a lot of research work is going on in solar and wind energy conversion systems for improving its performance. Over the past few years the installation of solar and wind has boosted much.

The rural villages that are hard to reach for the national grid can be electrified by standalone RETs such as solar home systems (SHS) and wind home systems (WHS).

Wind and solar are dependent sources and to cope with its unreliable nature extra cost is put in the form of storage. We have rivers gushing from the Himalaya to the Arabian Sea and many hydro power projects are built on these rivers, tapping its potential energy for generating electricity.

The estimated theoretical potential of hydropower in Pakistan is 41.5GW, just 16% of this huge capacity is tapped so far. Micro hydro potential of the northern areas of Pakistan is estimated to be about 500MW [6-8]. Although having abundant resources there are many areas that either have no grid electricity or experience low voltages due to being faraway from grid. Implementing a local solution for electricity will help these communities flourish also the load on central grid can be reduced.

Hydropower is a cheap form of energy production due to very low running cost. But due to very high initial cost and other problems that the reservoirs pose, it has lost its charm. As an alternate we can go for hydrokinetic energy system that utilizes the kinetic energy of the flowing water and doesn't need much of the civil work that the conventional hydro generation systems demand.

This crises has affected not only the daily life standard but equally or more severely the industry. The inflation has increased over the years and the use of thermal resources for power generation is costing a lot to the nation. The already crippling industry is on the verge of death due to the persistent

situation. Importing oil was never a viable option for us and the recent increase in the oil import has deteriorated the balance between imports and exports. Therefore the already available resources of Pakistan has to be exploited for electricity generation to lessen the import of oil for generation purposes. Other than the global trend towards clean energy resources, it is our necessity to exploit our indigenous resources for an overall balance [9]. In the past few years steps have been taken on the governmental level towards clean energy production.

## II. INTRODUCTION

Simply stating hydrokinetic energy is the energy of moving water. Hydrokinetic turbines get its energy from the water current, it may be from waves, tidal currents or canals. This is the main difference between a hydropower and hydrokinetic production, hydropower uses the hydraulic head of water while hydrokinetic uses the kinetic energy of the running water for producing electricity. Hydrokinetic generation is similar to that of wind energy generation system. The difference to wind is the speed of water, which is quite lower than that of wind but the water density adds to the significance of hydrokinetics which is about 800 times more than that of air. Also it is more concentrated and reliable than wind.

Hydrokinetic technology is a promising clean energy source. And has distinct advantages over other existing resources. One of the capability of hydrokinetics is its adaptability. Hydrokinetic turbine can be placed in the already existing water channels thus the expense of infrastructure can be reduced. Other being the time of installation that is, a hydrokinetic system can be installed in much lesser time and it can start production quickly. Also the cost for setting up a hydrokinetic system is much lower than for the same amount of solar or wind production. Constructing a dam may render more power but the land and resources required are quite considerable and that part of land cannot be then used for any other purposes. A hydrokinetic system on the other hand require much less space and do not alter the flow direction.

Many rivers and canal structures are available for relatively easy and burden-free use by hydrokinetic turbines to produce clean energy. Land requirement and high cost for infrastructure are rarely obstacles for hydrokinetic energy.

One of the concern that hover over all of the renewable energy resources is the inconsistency of the output. Investors are generally reluctant to invest on dependent sources of renewable energy due to the fluctuating amounts of energy produced, that are difficult to

predict accurately. This fear slows down investment on new technologies and especially renewable sources that are dependent mainly. This risk is not involved in hydrokinetics, hydrokinetic turbines are installed in streamlines or man-made structures which have consistent water flows throughout the year. Some canals may have a lower flow or a drought period, usually the energy extracted from most of the canals can be predicted. This is a major advantage over other renewable energy resources, and makes hydrokinetic energy more appealing, proving its potential for substantial growth. Although these distinct advantages prove hydrokinetic at an edge from other clean energy sources; the shadow of

hydropower has affected its growth. The clear difference between hydropower and hydrokinetic need to be put forward to enable its growth and general acceptance as a clean non-polluting source. Hydrokinetic systems for sure pose a worthwhile alternative to hydropower. It doesn't pose any of hydropower's problems to the environment (the environmental impact of hydrokinetic system is still not very much known). Despite the differences between a conventional hydropower and hydrokinetic systems, they can work very well together. Hydrokinetic can piggyback the traditional hydropower stations. The canals that emanates from the dams are most suitable for generating electricity through hydrokinetics. Studies and surveys are already completed for such sites and hydrokinetic can piggyback by using the already existing channels.

Hydrokinetic can be called a relatively new field in the domain of power generation. Researches all over the world is focusing mainly to achieve more efficient systems in terms of cost and power generation. Different types of turbine designs are in line for different applications. Areas with different speeds and other parameters are measured and the design of more efficient systems for power generation is acquired. In addition to harnessing the energy of the rivers there is a greater tendency towards the oceanic waves. Also making hybrid systems of more than one renewable resources like hybridizing wind and hydrokinetic system. A hydrokinetic system is usually for the local use therefore it works as an isolated system. Isolated systems are getting popular nowadays. Sites with less turbulence and flow continuous for whole year are best suited for hydrokinetics.

Since hydrokinetics system is designed for slow running volumes of water it can be applied to canal system and man-made streams. In Pakistan where the canal system is stretched over thousands of miles, deploying such systems will help in generating electricity for various purposes like for local needs, battery charging, and checking flow control for water levels in canals or for supplying energy for operate drip irrigation. Drip irrigation is efficient technique of farming, it saves water and is more efficient. In fast flowing rivers like river swat, extracting more power will help in meeting more purposes like heating water or pumping can be met through such system.

Standalone systems like wind and solar energy systems are implemented with batteries to deal with the problems of reliability. In the absence of sun light like at night the storage is used for supporting loads. In wind systems the storage helps in coping the problem of reliability and also at times when there is no load, the batteries act as load to the system because running a turbine system on no-load can torn out the blades quickly. On the other hand hydrokinetic systems are implemented for streams or currents that are exhibit known speeds and are steady throughout the year, a battery system is an extra burden both cost wise and maintenance wise in implementing a hydrokinetic system therefore avoided in this work.

## III. DESIGN METHODOLOGY

A great deal of research is going on in the world on hydrokinetics. In this paper a topology is proposed for

obtaining fixed voltage equal to battery that is equal to 12 volts. Changing of water speeds affect the voltage and power significantly, during different seasons of the year the water speed vary much and this in turn effect the voltage generated. In this paper we have come up with a solution to this problem. An AC generator is put in place, the output of this generator is rectified i-e changed to DC. This DC is then regulated and maintained at a fix level of 12V. We can then use this as power coming from a battery, as this is a constant 12V, or we can change this to a fixed AC by a home-inverter. Thus we can obtain a fixed AC from the changing water current with a simple technique and low cost.

Different components needed are; turbine for extracting energy, generator for converter that mechanical energy to electrical and then the control circuitry to regulate this voltage.

### A. Mechanical design

Mechanical design comprises of turbine and generator section in this hydrokinetic system.

#### 1) Turbine

Hydrokinetic turbines are mainly derived from its wind energy counter parts. They can be categorized into two categories of horizontal and vertical axis. On water flow basis they can be either vertical axis or horizontal axis turbines or they can be cross-flow [10]. Turbines are also classified as lift/drag nature, Equation for turbine power

$$P = C_p \frac{1}{2} \rho A v^3$$

A thorough detail of turbines is given in [11-14]. Turbine selection is not part of this study. The purpose of this study is to present an overall efficient system for generating hydro-power. A single turbine for different set of applications will affect the overall efficiency of the system. For different applications different turbine should be selected based on the requirement and condition of the water body. In the papers mentioned, different employability techniques are discussed and turbine selection will based on that research. Our aim in this paper is beyond turbine, the efficiency of the overall system by selecting proper generator and the control circuitry to achieve better power quality without interruptions and variations

#### 2) Generator

Permanent magnet synchronous generator is a best choice due to its many benefits. PMSG has high efficiency and requires low maintenance as discussed in [15] and [16]. For this test therefore a permanent magnet generator was selected.

### B. Electrical design

For the said application a converter was needed that has greater conversion ratio because the generator's output has to brought down to 12V also with less ripples so that the output is ripple free and a smooth inverter action takes place like that of a 12V battery to inverter. Bulky circuits are hard to mount therefore we needed a circuit that has lower switching losses so that if we increase the frequency for the purpose of minimizing the inductor and capacitor sizes, the losses do not go up. For large conversion ratios normally isolated DC-DC converters are preferred[17]. These converters are low cost

and easy to make but they are more suitable for small power applications. For greater power their losses go up rapidly and the leakage losses also increases. Simple buck converter is also not suitable because as the conversion ratio becomes smaller the efficiency goes down with it. Efficiency is highly desirable in this application therefore a multi-phase buck converter is used in this application. Two phase buck converter is similar to a half bridge converter. The input voltage is split in the two phases by a series capacitor thus the duty ratio becomes half of the normal buck converter[18].

The circuit shown in figure 1 is a two-phase buck converter. A capacitor inserted between switch\_1 and inductor L1, we call this additional capacitor as  $C_a$ . Switch 1 and 2 are operated with 180° of phase shift and a duty cycle less than 0.5. The circuit has four states of operation.

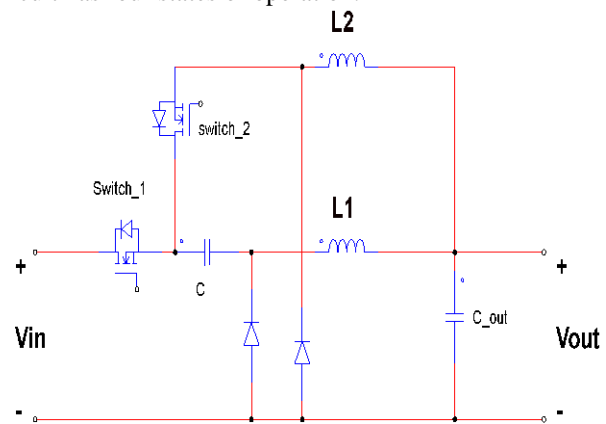

Figure 1. Circuit diagram of two-phase buck converter

In state 1, switch\_1 is turned ON, inductor L1 is connected to the input and output capacitor and also to  $C_a$  in the first state. The input voltage to phase 1 is lower than the input voltage as it is source voltage  $E_i$  minus the voltage of the the additional capacitor,  $V_{Ca}$ . The stored energy in the inductor and its current rises as depicted by the equation,

$$\Delta i_{L1on} = \frac{(E_i - V_{Ca} - E_o) T_{ON}}{L1} \quad (1)$$

Switch 1 is then turned OFF and it remains OFF during states 2-4. Now inductor L1 get connected to the output capacitor and the inductor current falls continuously in a linear manner, given by the equation,

$$\Delta i_{L1OFF} = \frac{E_o T_{OFF}}{L1} \quad (2)$$

The repetitions of this triangular waveform continues in cycles.

In state 3, second switch of the phase 2 is turned ON. L2 is connected with  $C_o$  and  $C_a$  through switch\_2 thus the input to this phase is now the voltage  $V_{Ca}$ . Change in current of L2 is as follows,

$$\Delta i_{L2on} = \frac{(V_{Ca} - E_o) T_{ON}}{L2} \quad (3)$$

In states 1, 2 and 4, switch\_2 is turned OFF. Inductor L2 is now in connection with the output capacitor and its current fall linearly as shown below,

$$\Delta i_{L2OFF} = \frac{E_0 T_{OFF}}{L_2} \quad (4)$$

This waveform which is triangular in shape is recurrent with 180° phase shift; the inductor currents are both added up in the output capacitor.

$$(E_i - V_{Ca} - E_0)T_{ON} - E_0 T_{OFF} = 0 \quad (5)$$

Also (3) and (4)

$$(V_{Ci} - E_0)T_{ON} - E_0 T_{OFF} = 0 \quad (6)$$

From equation (5) and (6) the capacitor voltage  $V_{Ca}$  is,

$$V_{Ca} = \frac{E_i}{2} \quad (7)$$

From equation (7) it can be inferred that the voltage of the additional capacitor  $C_a$  becomes half of the input voltage, hence in state 1 where switch\_1 is turned ON, the input voltage is shown as the input source voltage detriments the  $V_{Ca}$ , in this manner input to the converter gets  $E_i/2$ , in state 3 the input voltage of phase 2 equals  $V_{Ca} = \frac{E_i}{2}$ , therefore in this manner the converter functions like a simple buck converter with an input halved i.e  $E_i/2$ .

The voltage conversion ratio is derived from (5) and (7) as,

$$\frac{E_o}{E_i} = \frac{1}{2} \frac{T_{ON}}{T_{ON} + T_{OFF}} = \frac{D}{2} \quad (8)$$

It is clear from this equation that the conversion ratio is halved as compared to that of a conventional buck. For a conversion ratio of  $D$  the duty cycle should be given twice. Current ripples are reduced.

In this converter the inductor currents are balanced automatically [19-20].

#### IV. EXPERIMENTAL SETUP AND RESULTS

Permanent magnet synchronous generator is used in this experiment for the testing of this circuit. Firstly the AC signal is rectified through a bridge rectifier to convert the incoming AC from the motor to a DC. A filtering capacitor is not incorporated to the output because the circuit that we designed was able to handle the ripples.

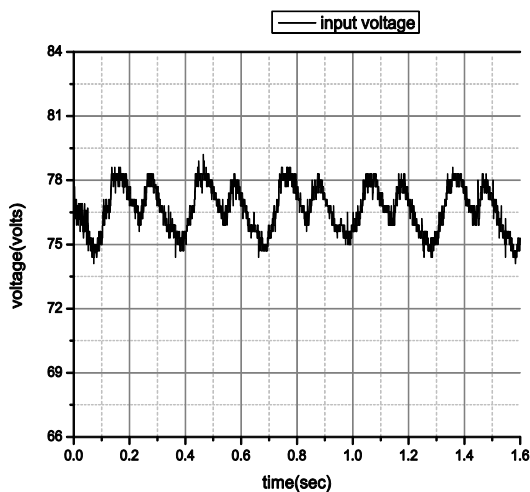

Figure 2. Output voltage waveform of the PMSG

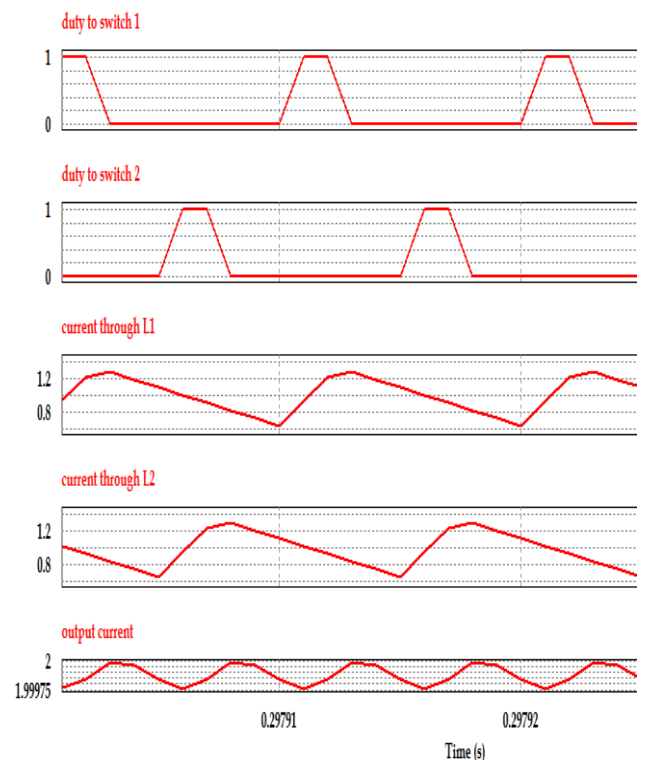

Figure 3. PSIM simulation results of the circuit

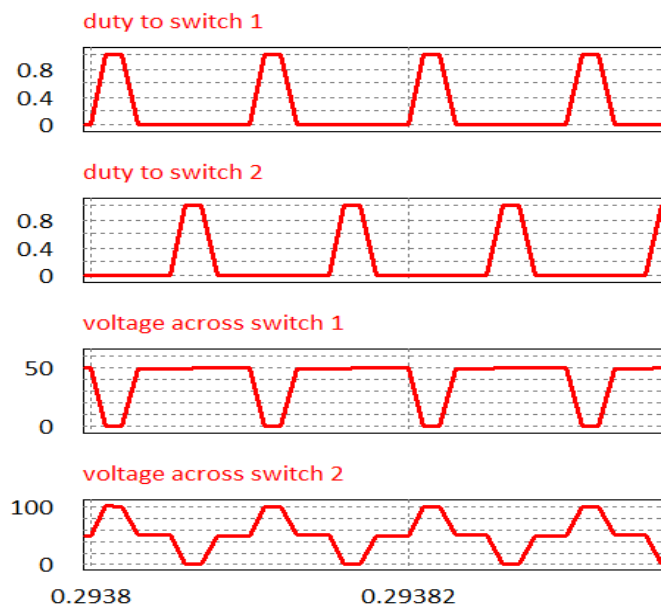

Figure 4. PSIM results for stress across switches

As evident from figure (3) and (4),

With this converter we were able to achieve;

(a) Conversion ratio of step down doubled ( $E_o/E_i = D/2$ ).

- (b) Reduction in losses of switching.
- (c) Minimizing voltage stress across switching elements.
- (d) Current ripple reduction.
- (e) Balanced inductor currents.
- (f) No need of current sensing part in the circuit.

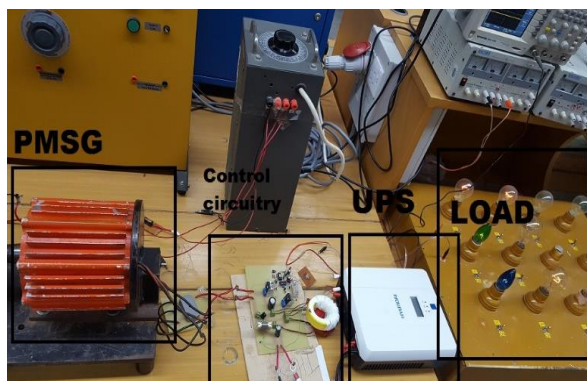

Figure 5. Experimental setup

#### CONCLUSION

From the above graphs it is evident that we have achieved our presented goals. The voltage stresses across the switches were low, the current was balanced and the output ripple free. The experimental setup is shown in the figure 5. All the results obtained in PSIM were verified in the experimental setup. A ripple free voltage was obtained through this circuit. Such type of systems can be implemented in the northern areas of Pakistan. In the northern areas there is tremendous resources that can be easily exploited through this technique. Most of the far northern areas are hard to reach for the national grid hence why some areas are even without electricity from the central grid and some, if have electricity from the grid, face severe low voltage problem. Through this technique these areas can be fed with electricity that would not fluctuate and hence beneficial for growth there. There is an option of scalability in this system also. If many such systems are installed over an area, we can arrange the overall output either in DC or AC microgrid or may be connected to the central grid, based upon the feasibility.

#### REFERENCES

- [1] Dudley, Bob. "BP statistical review of world energy." London, UK (2012).
- [2] Hartwick, John M. "Natural resources, national accounting and economic depreciation." *Journal of public Economics* 43.3 (1990): 291-304.
- [3] Awan, Ahmad Bilal, and Zeeshan Ali Khan. "Recent progress in renewable energy—Remedy of energy crisis in Pakistan." *Renewable and Sustainable Energy Reviews* 33 (2014): 236-253.
- [4] Khalil, Hafiz Bilal, and Syed Jawad Hussain Zaidi. "Energy crisis and potential of solar energy in Pakistan." *Renewable and Sustainable Energy Reviews* 31 (2014): 194-201.
- [5] Asif, Muhammad. "Energy crisis in Pakistan: Origins, challenges, and sustainable solutions." OUP Catalogue (2012).

- [6] Masood, Muhammad Tahir, and Fawad Shah. "Dilemma of third world countries-problems facing pakistan energy crisis a case-in-point." *International Journal of Business and Management* 7.5 (2012): 231.
- [7] Yazhou, Lei. "Studies on wind farm integration into power system [J]." *Automation of Electric Power Systems* 27.8 (2003): 84-89.
- [8] Bhutta, Muhammad Mahmood Aslam, et al. "Vertical axis wind turbine—A review of various configurations and design techniques." *Renewable and Sustainable Energy Reviews* 16.4 (2012): 1926-1939.
- [9] Shakeel, Shah Rukh, Josu Takala, and Waqas Shakeel. "Renewable energy sources in power generation in Pakistan." *Renewable and Sustainable Energy Reviews* 64 (2016): 421-434.
- [10] Rauf, Omer, et al. "An overview of energy status and development in Pakistan." *Renewable and Sustainable Energy Reviews* 48 (2015): 892-931.
- [11] Kusakana, Kanzumba, and Herman Jacobus Vermaak. "Hydrokinetic power generation for rural electricity supply: Case of South Africa." *Renewable energy* 55 (2013): 467-473.
- [12] Behrouzi, Fatemeh, et al. "Global renewable energy and its potential in Malaysia: A review of Hydrokinetic turbine technology." *Renewable and Sustainable Energy Reviews* 62 (2016): 1270-1281.
- [13] Chica, E., et al. "Design of a hydrokinetic turbine." *WIT Trans. Ecol. Environ* 195 (2015): 137-148.
- [14] Lago, L. I., F. L. Ponta, and L. Chen. "Advances and trends in hydrokinetic turbine systems." *Energy for sustainable development* 14.4 (2010): 287-296.
- [15] De Battista, Hernan, Ricardo J. Mantz, and Carlos F. Christiansen. "Dynamical sliding mode power control of wind driven induction generators." *IEEE Transactions on Energy Conversion* 15.4 (2000): 451-457.
- [16] Malinowski, Mariusz, Marian P. Kazmierkowski, and Andrzej M. Trzynadlowski. "A comparative study of control techniques for PWM rectifiers in AC adjustable speed drives." *IEEE Transactions on power electronics* 18.6 (2003): 1390-1396.
- [17] Hansen, Anca D., and Gabriele Michalke. "Modelling and control of variable-speed multi-pole permanent magnet synchronous generator wind turbine." *Wind Energy: An International Journal for Progress and Applications in Wind Power Conversion Technology* 11.5 (2008): 537-554.
- [18] Barnes, Arthur K., Juan C. Balda, and Corris M. Stewart. "Selection of converter topologies for distributed energy resources." 2012 Twenty-Seventh Annual IEEE Applied Power Electronics Conference and Exposition (APEC). IEEE, 2012.
- [19] Nishijima, K & Harada, K & Nakano, T & Nabeshima, Toshitaka & Sato, T. (2005). Analysis of Double Step-Down Two-Phase Buck Converter for VRM. 497 - 502. 10.1109/INTLEC.2005.335149.
- [20] Wu, Wenkai, Nai-Chi Lee, and George Schuellein. "Multi-phase buck converter design with two-phase coupled inductors." Twenty-First Annual IEEE Applied Power Electronics Conference and Exposition, 2006. APEC'06. IEEE, 2006.



**Muhammad Safdar** Buner Khyber Pakhtoonkhwa, March 30, 1992. MSC Electrical Energy Systems Engineering, USPCAS-E University of Engineering and Technology, Peshawar, Pakistan. 2019. BSC Electrical Engineering, University of Engineering and Technology, Peshawar, Pakistan. 2015.